

Air Cylinder

CA2 Series

ø40, ø50, ø63, ø80, ø100

RoHS

Reduced weight by changing the shape of the rod cover and head cover.

Weight reduced by up to

(ø50-50 stroke)
15% lighter

1.31 kg

1.54 kg
Current model



Easy air cushion control

Number of cushion valve adjustment rotations increased from 1 rotation to **3 rotations**.

Fine adjustment becomes easy, **ensuring smooth operation at the stroke end**.

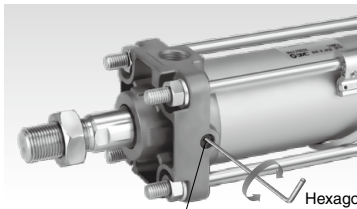

Cushion valve

Hexagon wrench

Various switches such as compact auto switches and magnetic field resistant auto switches can be mounted.

Compact auto switches

- D-M9□
- D-A9□

Magnetic field resistant auto switches

- D-P3DWA
- D-P4DW

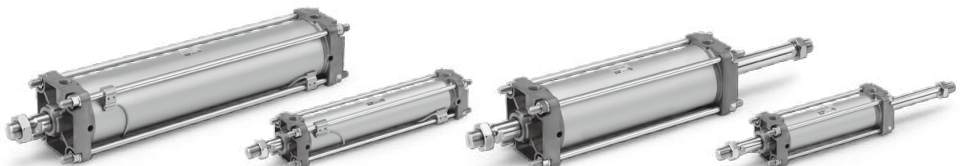
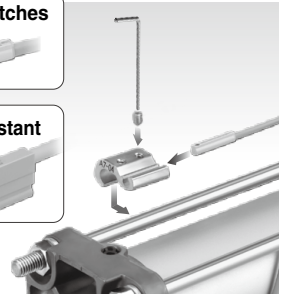

| |
|------------|
| CJ1 |
| CJP |
| CJ2 |
| JCM |
| CM2 |
| CM3 |
| CG1 |
| CG3 |
| JMB |
| MB |
| MB1 |
| CA2 |
| CS1 |
| CS2 |

| |
|----------------|
| D-□ |
| -X□ |
| Technical Data |

Part numbers with rod end bracket and/or pivot bracket available

Not necessary to order a bracket for the applicable cylinder separately

Note) Mounting bracket is shipped together with the product, but not assembled.

Example) CDA2 **D** 40-100Z- **N W** -M9BW

● Mounting

Pivot bracket

| | |
|------------|--|
| Nil | None |
| N | Pivot bracket is shipped together with the product, but not assembled. |

* Applicable to only mounting D (Double clevis) and T (Center trunnion).

N: Kit of pivot bracket and double clevis



T: Kit of pivot bracket and trunnion



Rod end bracket

| | |
|------------|----------------------|
| Nil | None |
| V | Single knuckle joint |
| W | Double knuckle joint |

With rod end bracket

V: Single knuckle joint **W:** Double knuckle joint

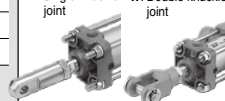

Various mounting bracket options

- Suitable mounting brackets can be selected for the installation condition.
- Improved amount of mounting freedom

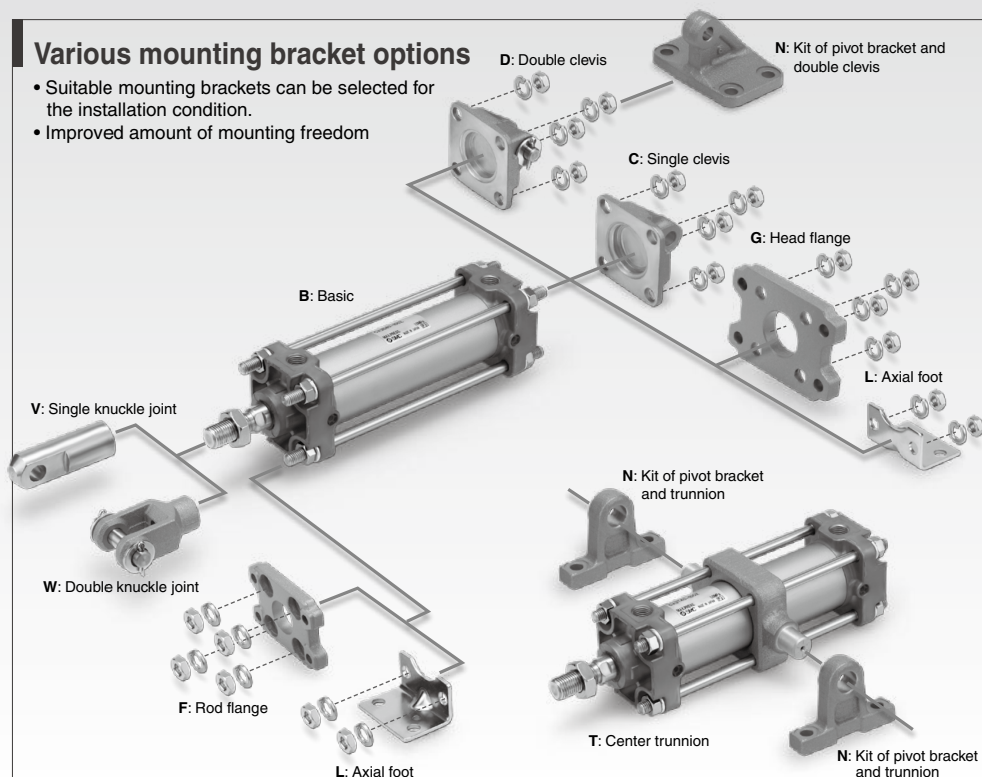

Reduced weight by changing the shape of the rod cover and head cover.

| Bore size (mm) | CA2 | Reduction rate | Current model (kg) |
|----------------|------|----------------|--------------------|
| 40 | 0.93 | 12% | 1.06 |
| 50 | 1.31 | 15% | 1.54 |
| 63 | 1.84 | 14% | 2.15 |
| 80 | 3.17 | 11% | 3.56 |
| 100 | 4.29 | 10% | 4.76 |

* Compared to 50 stroke for each size

No substances hazardous to the environment are used.

Lead free bushing is used as sliding material.
Compliant with EU RoHS directive.

Mounting dimensions are the same as the current product.

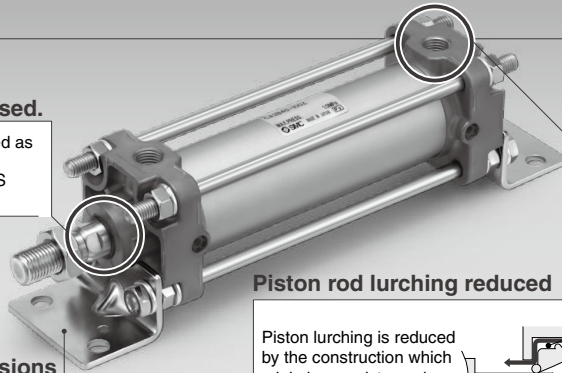

Piston rod lurching reduced

Piston lurching is reduced by the construction which minimizes resistance in the air passage at startup.

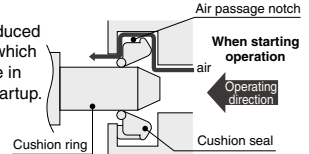

Stroke Variations

| Bore size (mm) | Standard stroke | | | | | | | | | | | | | | | | |
|----------------|-----------------|----|----|-----|-----|-----|-----|-----|-----|-----|-----|-----|-----|-----|-----|-----|------------|
| | 25 | 50 | 75 | 100 | 125 | 150 | 175 | 200 | 250 | 300 | 350 | 400 | 450 | 500 | 600 | 700 | Up to 1800 |
| 40 | ● | ● | ● | ● | ● | ● | ● | ● | ● | ● | ● | ● | ● | ● | ● | ● | |
| 50 | ● | ● | ● | ● | ● | ● | ● | ● | ● | ● | ● | ● | ● | ● | ● | ● | |
| 63 | ● | ● | ● | ● | ● | ● | ● | ● | ● | ● | ● | ● | ● | ● | ● | ● | |
| 80 | ● | ● | ● | ● | ● | ● | ● | ● | ● | ● | ● | ● | ● | ● | ● | ● | |
| 100 | ● | ● | ● | ● | ● | ● | ● | ● | ● | ● | ● | ● | ● | ● | ● | ● | |

Series Variations

| Series | Type | Bore size (mm) | | | | | Variations | | Page |
|-----------------------------------|------------|----------------|----|----|----|-----|---------------|-----------------|--|
| | | 40 | 50 | 63 | 80 | 100 | With rod boot | Water resistant | |
| Standard CA2-Z | Single rod | ● | ● | ● | ● | ● | ● | ● | Page 470 |
| | Double rod | ● | ● | ● | ● | ● | ● | ● | Page 486 |
| Non-rotating rod CA2K | Single rod | ● | ● | ● | ● | ● | ● | ● | Page 494 |
| | Double rod | ● | ● | ● | ● | ● | ● | ● | Page 498 |
| With end lock CBA2 | Single rod | ● | ● | ● | ● | ● | ● | ● | Page 502 |
| Air-hydro CA2□H | Single rod | ● | ● | ● | ● | ● | ● | ● | Page 508 |
| | Double rod | ● | ● | ● | ● | ● | ● | ● | Page 512 |
| Smooth Cylinder CA2Y-Z | Single rod | ● | ● | ● | ● | ● | ● | ● | Best Pneumatics No. 2-3 |
| Low friction CA2□Q | Single rod | ● | ● | ● | ● | ● | ● | ● | Use the new series "Smooth Cylinder CA2Y Series" to realize both-direction low friction and low-speed operation. (Refer to the Best Pneumatics No. 2-3.) |

* For details about the clean series, refer to the "Pneumatic Clean Series" (CAT.E02-23).

CG1

CGP

CG2

JCM

CM2

CM3

CG1

CG3

JMB

MB

MB1

CA2

CS1

CS2

D-□

-X□

Technical Data

Combinations of Standard Products and Made to Order Specifications

CA2 Series

- : Standard
- : Made to Order
- : Special product (Please contact SMC for details.)
- : Not available

| Series | CA2 (Standard type) | | CA2K ^{Note 4)} (Non-rotating rod type) | | Page | |
|-----------------|---|------------|--|------------|------|--|
| | Double acting | | | | | |
| | Single rod | Double rod | Single rod | Double rod | | |
| Action/ Type | Page 470 | Page 486 | Page 494 | Page 498 | | |
| Page | Page 470 | Page 486 | Page 494 | Page 498 | | |
| Standard | Standard | — | | | | |
| CDA2-□Z | Built-in magnet | ● | ● | ● | ● | |
| Long st | Long stroke | ● | ● | ● | ● | |
| CA2□-□JZ | With rod boot (Nylon tarpaulin) | ● | ● | ○ | ○ | |
| CA2□-□KZ | With rod boot (Heat resistant tarpaulin) | ● | ● | ● | ● | |
| 10-, 11- | Clean series ^{Note 4)} | ● | ○ | — | — | |
| 25A- | Copper (Cu) and Zinc (Zn)-free ^{Note 1)} | ● | ○ | — | — | |
| 20- | Copper ^{Note 2)} and Fluorine-free | ● | ● | ● | ● | |
| CA2□R | Water resistant (NBR seal) | ● | ○ | — | — | |
| CA2□V | Water resistant (FKM seal) | ● | ○ | — | — | |
| CA2□M | Cylinder with stable lubrication function (Lube-retainer) | ● | ○ | — | — | |
| XA□ | Change of rod end shape | ○ | ○ | ○ | ○ | |
| XB5 | Oversized rod cylinder ^{Note 4)} | ○ | ○ | — | — | |
| XB6 | Heat resistant cylinder (-10 to 150°C) | ○ | ○ | — | — | |
| XC3 | Special port location ^{Note 4)} | ○ | ○ | ○ | ○ | |
| XC4 | With heavy duty scraper | ○ | ○ | — | — | |
| XC5 | Heat resistant cylinder (-10 to 110°C) | ○ | ○ | — | — | |
| XC6 | Made of stainless steel ^{Note 4)} | — | — | — | — | |
| XC7 | Tie-rod, cushion valve, tie-rod nut, etc. made of stainless steel | ○ | ○ | ○ | ○ | |
| XC8 | Adjustable stroke cylinder/Adjustable extension type | ○ | — | ○ | ○ | |
| XC9 | Adjustable stroke cylinder/Adjustable retraction type | ○ | — | ○ | — | |
| XC10 | Dual stroke cylinder/Double rod type | ○ | — | ○ | — | |
| XC11 | Dual stroke cylinder/Single rod type | ○ | ○ | ○ | — | |
| XC12 | Tandem cylinder | ○ | ○ | ○ | — | |
| XC14 | Change of trunnion bracket mounting position | ○ | ○ | ○ | ○ | |
| XC15 | Change of tie-rod length | ○ | ○ | ○ | ○ | |
| XC22 | Fluororubber seal | ○ | ○ | — | — | |
| XC27 | Double clevis and double knuckle joint pins made of stainless steel | ○ | — | ○ | — | |
| XC28 | Compact flange made of SS400 | ○ | ○ | ○ | ○ | |
| XC29 | Double knuckle joint with spring pin | ○ | ○ | ○ | ○ | |
| XC30 | Rod trunnion | ○ | ○ | ○ | ○ | |
| XC35 | With coil scraper | ○ | ○ | — | — | |
| XC65 | Made of stainless steel (Combination of XC7 and XC68) | ○ | ○ | — | — | |
| XC68 | Made of stainless steel (with hard chrome plated piston rod) | ○ | ○ | — | — | |
| XC85 | Grease for food processing equipment | ○ | ○ | ○ | ○ | |
| XC88 | Spatter resistant coil scraper, Lube-retainer, Grease for welding (Piston rod: Stainless steel 304) | ○ | ○ | — | — | |
| XC89 | Spatter resistant coil scraper, Lube-retainer, Grease for welding (Piston rod: S45C) | ○ | ○ | — | — | |
| XC91 | Spatter resistant coil scraper, Grease for welding (Piston rod: S45C) | ○ | ○ | — | — | |
| X1184 | Cylinder with heat resistant reed auto switch (-10 to 120°C) | ○ | — | — | — | |

Note 1) For details, refer to the **Web Catalog**.
 Note 2) Copper-free for the externally exposed part. For details, refer to the **Web Catalog**.
 Note 3) For details about the smooth cylinder, refer to the Best Pneumatics No. 2-3.
 Note 4) The cover shape is the same as the current product.

Use the new series "Smooth Cylinder CA2Y Series" to realize both-direction low friction and low-speed operation. (Refer to the Best Pneumatics No. 2-3.)

| CBA2 <small>Note 4)</small> (With end lock) | | CA2□H <small>Note 4)</small> (Air-hydro type) | | CA2Y <small>Note 3)</small> (Smooth Cylinder) | CA2□Q <small>Note 4)</small> (Low friction type) | |
|--|--------------------------|--|-------------------------|--|---|----------|
| Double acting | | | | | | |
| Single rod | Single rod | Double rod | Single rod | Single rod | | Symbol |
| Page 502 | Page 508 | Page 512 | Best Pneumatics No. 2-3 | Page 516 | | |
| | | — | | | | Standard |
| ● | ● | ● | ● | ● | ● | CDA2-□Z |
| ● | ● | ● | ○ | ○ | ○ | Long st |
| ● | ● | ● | ○ | ○ | ○ | CA2□-□JZ |
| ● | ● | ● | ○ | ○ | ○ | CA2□-□KZ |
| ● <small>Note 5)</small> | — | — | — | — | — | 10-, 11- |
| — | — | — | ⊙ | — | — | 25A- |
| ● | ○ | ○ | — | — | — | 20- |
| ● <small>Note 5)</small> | ○ | ○ | — | — | — | CA2□R |
| ● <small>Note 5)</small> | ○ | ○ | — | — | — | CA2□V |
| — | — | — | — | — | — | CA2□M |
| ○ | ○ | ○ | ⊙ | ⊙ | — | XA□ |
| ○ | ○ | ○ | — | — | — | XB5 |
| ○ | — | — | — | — | — | XB6 |
| ○ | ○ | ○ | — | — | ⊙ <small>Note 8)</small> | XC3 |
| ⊙ <small>Note 5)</small> | ⊙ <small>Note 7)</small> | ⊙ <small>Note 7)</small> | — | — | — | XC4 |
| ○ | — | — | — | — | — | XC5 |
| ⊙ <small>Note 5)</small> | ⊙ | ⊙ | — | — | — | XC6 |
| ⊙ | ○ | ○ | ⊙ | ⊙ | — | XC7 |
| ⊙ <small>Note 5)</small> | ○ | — | ○ | ○ | — | XC8 |
| ⊙ <small>Note 6)</small> | ○ | — | ○ | ⊙ | — | XC9 |
| ⊙ | ○ | — | ○ | ⊙ | — | XC10 |
| ○ | ○ | ○ | ○ | ○ | — | XC11 |
| ○ | ○ | ○ | — | — | — | XC12 |
| ○ | ⊙ | ⊙ | ⊙ | ⊙ | — | XC14 |
| ○ | ⊙ | ⊙ | ⊙ | ⊙ | — | XC15 |
| ○ | ○ | — | — | — | — | XC22 |
| ⊙ | ○ | — | ⊙ | ⊙ | — | XC27 |
| ⊙ | ○ | ○ | ⊙ | ⊙ | — | XC28 |
| ⊙ | ○ | ○ | ⊙ | ⊙ | — | XC29 |
| — | ○ | ○ | ⊙ | ⊙ | — | XC30 |
| ⊙ | ○ | ○ | — | — | — | XC35 |
| ○ | ○ | ○ | ⊙ | ⊙ | — | XC65 |
| — | — | — | ⊙ | — | — | XC68 |
| ○ | — | — | — | — | — | XC85 |
| ○ | — | — | — | — | — | XC88 |
| ○ | — | — | — | — | — | XC89 |
| ○ | — | — | — | — | — | XC91 |
| ○ | — | — | — | — | — | X1184 |

Note 5) Available only for locking at head end.

Note 6) Available only for locking at rod end.

Note 7) Standard for the air-hydro type

Note 8) CA2□Q series has no cushion. Only XC3BC, XC3CD and XC3DA are available.

- CJ1
- CJP
- CJ2
- JCM
- CM2
- CM3
- CG1
- CG3
- JMB
- MB
- MB1
- CA2
- CS1
- CS2

- D-□
- X□
- Technical Data

Air Cylinder: Standard Type Double Acting, Single Rod

CA2 Series

ø40, ø50, ø63, ø80, ø100

RoHS

How to Order

CA2 B **50** - **100** **Z** - -

With auto switch **CDA2 B** **50** - **100** **Z** - - **M9BW** -

With auto switch (Built-in magnet)

Mounting

| | |
|----------|-----------------|
| B | Basic |
| L | Axial foot |
| F | Rod flange |
| G | Head flange |
| C | Single clevis |
| D | Double clevis |
| T | Center trunnion |

* Mounting brackets other than center trunnion are shipped together.

Bore size

| | |
|------------|--------|
| 40 | 40 mm |
| 50 | 50 mm |
| 63 | 63 mm |
| 80 | 80 mm |
| 100 | 100 mm |

Port thread type

| | |
|------------|-----|
| Nil | Rc |
| TN | NPT |
| TF | G |

* Not available with auto switch.

Tube material

| | |
|------------|---------------|
| Nil | Aluminum tube |
| F* | Steel tube |

* Not available with auto switch.

Cylinder stroke (mm)

For details, refer to the next page.

Bracket 1

| | |
|------------|-----------------|
| Nil | Without bracket |
| N | Pivot bracket |

* Only for D and T mounting types.
* Pivot bracket is shipped together with the product, but not assembled.

Suffix (Cushion)

| | |
|------------|---------------|
| Nil | Air cushion |
| N | Rubber bumper |

Suffix (Rod boot)

| | |
|------------|--------------------------|
| Nil | None |
| J | Nylon tarpaulin |
| K | Heat resistant tarpaulin |

Auto switch

| | |
|------------|----------------------|
| Nil | Without auto switch |
| V | Single knuckle joint |
| W | Double knuckle joint |

* For applicable auto switches, refer to the table below.

Bracket 2

| | |
|------------|----------------------|
| Nil | Without bracket |
| V | Single knuckle joint |
| W | Double knuckle joint |

* A knuckle joint pin is not provided with the single knuckle joint.
* Rod end bracket is shipped together with the product, but not assembled.

Number of auto switches

| | |
|------------|----------|
| Nil | 2 pcs. |
| S | 1 pc. |
| 3 | 3 pcs. |
| n | "n" pcs. |

Made to Order

For details, refer to the next page.

Applicable Auto Switches/Refer to pages 1575 to 1701 for further information on auto switches.

| Type | Special function | Electrical entry | Indicator (opt) | Wiring (Output) | Load voltage | | Auto switch model | | Lead wire length (m) | | | Pre-wired connector | Applicable load | |
|--|--|------------------|-------------------------|-----------------|--------------|-----------|-------------------|---------------|----------------------|-------|-------|---------------------|-----------------|------------|
| | | | | | DC | AC | Tie-rod mounting | Band mounting | 0.5 (Nil) | 1 (M) | 3 (L) | | | 5 (Z) |
| Solid state auto switch | — | Grommet | — | 3-wire (NPN) | 24 V | 5 V, 12 V | — | M9N | ● | ● | ○ | ○ | IC circuit | — |
| | | | | 3-wire (PNP) | | | | G59 | ● | ● | ○ | ○ | | |
| | | | | 2-wire | | | | M9P | ● | ● | ○ | ○ | | |
| | | Terminal conduit | | 3-wire (NPN) | | | | G5P | ● | ● | ○ | ○ | | |
| | | | | 2-wire | | | | M9B | ● | ● | ○ | ○ | | |
| | | | | 3-wire (PNP) | | | | K59 | ● | ● | ○ | ○ | | |
| | Diagnostic indication (2-color indicator) | Grommet | Yes | 3-wire (NPN) | 24 V | 5 V, 12 V | — | G39C | ● | ● | ○ | ○ | IC circuit | Relay, PLC |
| | | | | 3-wire (PNP) | | | | G39 | ● | ● | ○ | ○ | | |
| | | | | 2-wire | | | | K39C | ● | ● | ○ | ○ | | |
| | | Terminal conduit | | 3-wire (NPN) | | | | M9NW | ● | ● | ○ | ○ | | |
| | | | | 2-wire | | | | G59W | ● | ● | ○ | ○ | | |
| | | | | 3-wire (PNP) | | | | M9PW | ● | ● | ○ | ○ | | |
| Water resistant (2-color indicator) | Grommet | — | 3-wire (NPN) | 24 V | 5 V, 12 V | — | M9NA*1 | — | ○ | ○ | ○ | — | — | |
| | | | 3-wire (PNP) | | | | M9PA*1 | — | ○ | ○ | ○ | | | |
| | | | 2-wire | | | | M9BA*1 | — | ○ | ○ | ○ | | | |
| | With diagnostic output (2-color indicator) | | 4-wire (NPN) | | | | G5BA*1 | — | ○ | ○ | ○ | | | |
| | | | 2-wire | | | | F59F | ● | ● | ○ | ○ | | | |
| | | | 2-wire (Non-polar) | | | | P3DWA | — | — | ● | ● | | | |
| Magnetic field resistant (2-color indicator) | Grommet | — | 3-wire (NPN equivalent) | 24 V | 5 V | — | P4DW | — | — | ● | ● | IC circuit | — | |
| | | | 2-wire | | | | A96 | — | ● | ● | — | | | |
| | | | 3-wire (NPN equivalent) | | | | A93 | — | ● | ● | — | | | |
| | Terminal conduit | | 100 V or less | | | | A90 | — | ● | ● | — | | | |
| | | | 100 V, 200 V | | | | A54 | B54 | ● | ● | ● | | | |
| | | | 200 V or less | | | | A64 | B64 | ● | ● | — | | | |
| DIN terminal | 100 V, 200 V | A33C | A33 | — | — | — | | | | | | | | |
| | — | A34C | A34 | — | — | — | | | | | | | | |
| | — | A44C | A44 | — | — | — | | | | | | | | |
| Diagnostic indication (2-color indicator) | Grommet | — | — | — | — | — | A59W | B59W | ● | — | — | — | — | |

*1 Water resistant type auto switches can be mounted on the above models, but in such case SMC cannot guarantee water resistance.

* A water-resistant type cylinder is recommended for use in an environment which requires water resistance.

* Lead wire length symbols: 0.5 m..... Nil (Example) M9NW * Solid state auto switches marked with "○" are produced upon receipt of order.

1 m..... M (Example) M9NWM
3 m..... L (Example) M9NWL
5 m..... Z (Example) M9NWX

* Since there are other applicable auto switches than listed above, refer to page 523 for details.

* For details about auto switches with pre-wired connector, refer to pages 1649 and 1649.

* The D-A9□/M9□□/P3DWA□ auto switches are shipped together, (but not assembled). (However, auto switch mounting brackets are assembled for the D-A9□/M9□□ before shipment.)



Symbol

Double acting

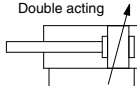

Air cushion



Made to Order: Individual Specifications
(For details, refer to page 524.)

| Symbol | Specifications |
|--------|--|
| -X1184 | Cylinder with heat resistant reed auto switch (-10 to 120°C) |

Made to Order

[Click here for details](#)

| Symbol | Specifications |
|--------|---|
| -XA | Change of rod end shape |
| -XB5 | Oversized rod cylinder* |
| -XB6 | Heat resistant cylinder (-10 to 150°C) |
| -XC3 | Special port location* |
| -XC4 | With heavy duty scraper |
| -XC5 | Heat resistant cylinder (-10 to 110°C) |
| -XC7 | Tie-rod, cushion valve, tie-rod nut, etc. made of stainless steel |
| -XC8 | Adjustable stroke cylinder/Adjustable extension type |
| -XC9 | Adjustable stroke cylinder/Adjustable retraction type |
| -XC10 | Dual stroke cylinder/Double rod type |
| -XC11 | Dual stroke cylinder/Single rod type |
| -XC12 | Tandem cylinder |
| -XC14 | Change of trunnion bracket mounting position |
| -XC15 | Change of tie-rod length |
| -XC22 | Fluororubber seal |
| -XC27 | Double clevis and double knuckle joint pins made of stainless steel |
| -XC28 | Compact flange made of SS400 |
| -XC29 | Double knuckle joint with spring pin |
| -XC30 | Rod trunnion |
| -XC35 | With coil scraper |
| -XC65 | Made of stainless steel (Combination of XC7 and XC68) |
| -XC68 | Made of stainless steel (with hard chrome plated piston rod) |
| -XC85 | Grease for food processing equipment |
| -XC88 | Spatter resistant coil scraper, Lube-retainer, Grease for welding (Piston rod: Stainless steel 304) |
| -XC89 | Spatter resistant coil scraper, Lube-retainer, Grease for welding (Piston rod: S45C) |
| -XC91 | Spatter resistant coil scraper, Grease for welding (Piston rod: S45C) |

For special port location (-XC3), the mounting bracket and port location can be determined using the standard product corresponding to the operating conditions.

* The cover shape is the same as the current product.

For made of stainless steel (-XC6), use made of stainless steel (with hard chrome plated piston rod) (-XC68) that the surface treatment is performed on the piston rod with the same specifications.

Refer to pages 517 to 523 for cylinders with auto switches.

- Auto switch proper mounting position (detection at stroke end) and its mounting height
- Operating range
- Minimum stroke for auto switch mounting
- Auto switch mounting brackets/Part no.

Specifications

| Bore size (mm) | | 40 | 50 | 63 | 80 | 100 | |
|---|---|----------------|------|------|-----|------|------|
| Fluid | Air | | | | | | |
| Action | Double acting | | | | | | |
| Proof pressure | 1.5 MPa | | | | | | |
| Maximum operating pressure | 1.0 MPa | | | | | | |
| Ambient and fluid temperature | Without auto switch: -10 to 70°C*1 With auto switch: -10 to 60°C*1 | | | | | | |
| Minimum operating pressure | 0.05 MPa | | | | | | |
| Piston speed | 50 to 500 mm/s | | | | | | |
| Cushion | Air cushion or Rubber bumper | | | | | | |
| Stroke length tolerance | Up to 250 st: $^{+1.0}_0$ 251 to 1000 st: $^{+1.4}_0$ 1001 to 1500 st: $^{+1.8}_0$ 1501 to 1800 st: $^{+2.2}_0$ | | | | | | |
| Lubrication | Not required (Non-lube) | | | | | | |
| Mounting | Basic, Foot, Rod flange, Head flange Single clevis, Double clevis, Center trunnion | | | | | | |
| Allowable kinetic energy (J) ^{1,2} | Air cushion | When activated | 2.8 | 4.6 | 7.8 | 16 | 29 |
| | When not activated | 0.33 | 0.56 | 0.91 | 1.5 | 2.68 | |
| | Rubber bumper | | 1.8 | 3.6 | 6.0 | 12.0 | 12.0 |

*1 No freezing

*2 Activate the air cushion when operating the cylinder. If this is not done, the piston rod assembly or the tie-rods will be damaged when the allowable kinetic energy exceeds the values shown in the above table.

Standard Strokes

| Bore size | Standard stroke ^{Note 1)} | | Max. manufacturable stroke (mm) |
|-----------|---|----------------|---------------------------------|
| | Stroke range ① | Stroke range ② | |
| 40 | 25, 50, 75, 100, 125, 150, 175, 200, 250, 300, 350, 400, 450, 500 | Up to 1800 | Up to 2700 |
| | 25, 50, 75, 100, 125, 150, 175, 200, 250, 300, 350, 400, 450, 500, 600 | | |
| 50, 63 | 25, 50, 75, 100, 125, 150, 175, 200, 250, 300, 350, 400, 450, 500, 600, 700 | | |
| | 25, 50, 75, 100, 125, 150, 175, 200, 250, 300, 350, 400, 450, 500, 600, 700 | | |

Note 1) Intermediate strokes not listed above are produced upon receipt of order.

Note 2) Applicable strokes should be confirmed according to the usage. For details, refer to "Air Cylinders Model Selection" on front matter pages. In addition, the products that exceed the stroke range ① might not be able to fulfill the specifications due to the deflection etc.

Note 3) Please consult with SMC for manufacturability and the part numbers when exceeding the stroke range ②.

Note 4) The stroke range with rod boot is 20 to 1800 mm. Please consult with SMC when exceeding 1800 mm strokes.

Note 5) Using a stroke of a length which is smaller than the effective cushion length may result in reduced air cushion performance. Refer to "Technical Data 1" on page 1901 for details on the effective cushion length.

Minimum Stroke for Auto Switch Mounting

⚠ Caution

The minimum stroke for mounting varies with the auto switch type and cylinder mounting type. In particular, the center trunnion type needs careful attention. (For details, refer to pages 521 and 522.)

Rod Boot Material

| Symbol | Rod boot material | Max. ambient temperature |
|--------|--------------------------|--------------------------|
| J | Nylon tarpaulin | 70°C |
| K | Heat resistant tarpaulin | 110°C ^b |

* Maximum ambient temperature for the rod boot

Accessories

| | Mounting | Basic | Axial foot | Rod flange | Head flange | Single clevis | Double clevis | Center trunnion |
|----------|---------------------------------|-------|------------|------------|-------------|---------------|---------------|-----------------|
| Standard | Rod end nut | ● | ● | ● | ● | ● | ● | ● |
| | Clevis pin | — | — | — | — | — | ● | — |
| | Single knuckle joint | ● | ● | ● | ● | ● | ● | ● |
| Option | Double knuckle joint (with pin) | ● | ● | ● | ● | ● | ● | ● |
| | With rod boot | ● | ● | ● | ● | ● | ● | ● |

* Refer to page 485 for part numbers and dimensions.

CJ1

CJP

CJ2

JCM

CM2

CM3

CG1

CG3

JMB

MB

MB1

CA2

CS1

CS2

D-□

-X□

Technical Data

CA2 Series

Ordering Example of Cylinder Assembly

Cylinder model:
CDA2D50-100Z-NW-M9BW

Mounting D: Double clevis
Pivot bracket N: Yes
Rod end bracket W: Double knuckle joint
Auto switch D-M9BW: 2 pcs.

* Pivot bracket, double knuckle joint and auto switch are shipped together with the product, but not assembled.

Weights/Aluminum Tube (Steel Tube)

| Bore size (mm) | | 40 | 50 | 63 | 80 | 100 | | |
|----------------|---------------------------------------|-----------------------|---------------|------|------|------|------|------|
| Basic weight | Basic | Aluminum tube | 0.73 | 1.06 | 1.53 | 2.73 | 3.71 | |
| | | Steel tube | 0.78 | 1.12 | 1.62 | 2.91 | 3.98 | |
| | Axial foot | Aluminum tube | 0.91 | 1.25 | 1.83 | 3.40 | 4.64 | |
| | | Steel tube | 0.96 | 1.31 | 1.92 | 3.58 | 4.91 | |
| | Flange | Aluminum tube | 1.09 | 1.48 | 2.28 | 4.18 | 5.57 | |
| | | Steel tube | 1.14 | 1.54 | 2.37 | 4.36 | 5.84 | |
| | Single clevis | Aluminum tube | 0.95 | 1.37 | 2.12 | 3.84 | 5.43 | |
| | | Steel tube | 1.00 | 1.43 | 2.21 | 4.02 | 5.70 | |
| | Double clevis | Aluminum tube | 0.99 | 1.46 | 2.28 | 4.13 | 5.95 | |
| | | Steel tube | 1.04 | 1.52 | 2.37 | 4.31 | 6.22 | |
| | Trunnion | Aluminum tube | 1.08 | 1.51 | 2.29 | 4.28 | 5.93 | |
| | | Steel tube | 1.13 | 1.57 | 2.38 | 4.46 | 6.20 | |
| | Additional weight per 50 mm of stroke | All mounting brackets | Aluminum tube | 0.20 | 0.25 | 0.31 | 0.46 | 0.58 |
| | | | Steel tube | 0.28 | 0.35 | 0.43 | 0.7 | 0.87 |
| Accessories | Single knuckle | 0.23 | 0.26 | 0.26 | 0.60 | 0.83 | | |
| | Double knuckle (with pin) | 0.37 | 0.43 | 0.43 | 0.87 | 1.27 | | |

Calculation:

Example) **CA2L40-100Z**

(Axial foot, ø40, 100 stroke)

- Basic weight.....0.91 kg
 - Additional weight.....0.20/50 stroke
 - Cylinder stroke 100 stroke
- $$0.91 + 0.20 \times 100/50 = 1.31 \text{ kg}$$

Mounting Brackets/Part No.

| Bore size (mm) | 40 | 50 | 63 | 80 | 100 |
|-----------------|---------|---------|---------|---------|---------|
| Axial foot* | CA2-L04 | CA2-L05 | CA2-L06 | CA2-L08 | CA2-L10 |
| Flange | CA2-F04 | CA2-F05 | CA2-F06 | CA2-F08 | CA2-F10 |
| Single clevis | CA2-C04 | CA2-C05 | CA2-C06 | CA2-C08 | CA2-C10 |
| Double clevis** | CA2-D04 | CA2-D05 | CA2-D06 | CA2-D08 | CA2-D10 |

* When axial foot brackets are used, order two pieces per cylinder.

** A clevis pin, flat washers and split pins are shipped together with double clevis.

Allowable Kinetic Energy

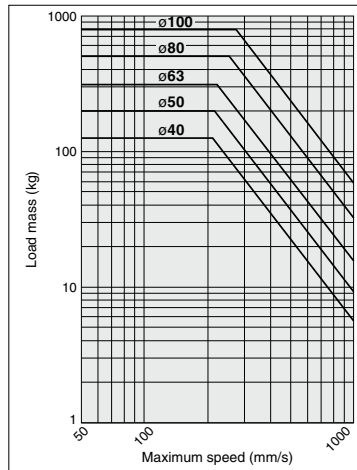

(Example) Find the upper limit of rod end load when an air cylinder of ø63 is operated at 500 mm/s.

From a point indicating 500 mm/s on the axis of abscissas, extend a line upward and find a point where it intersects with a line for the 63 mm bore size. Extend a line from the intersection to the left and find a load mass 60 kg.

Water Resistant

| | | | | | | | | |
|------|---------------------------------------|------------------------------|---------------------------|----------|--------|----------|---|---------------|
| CDA2 | Mounting type | Bore size | Port thread type | R | Stroke | Suffix Z | M9□A(V)L | -XC68 |
| | With auto switch (Built-in magnet) | | | | | | Water resistant 2-color indicator solid state auto switch | Made to Order |
| | | Water resistant air cylinder | | | | | | |
| | | R | NBR seal (Nitrile rubber) | | | | | |
| | | V | FKM seal (Fluororubber) | | | | | |

Specifications

| | |
|----------------------|---|
| Action | Double acting, Single rod |
| Bore size (mm) | 40, 50, 63, 80, 100 |
| Cushion | Air cushion |
| Auto switch mounting | Tie-rod mounting |
| Made to Order | XC68: Made of stainless steel (with hard chrome plated piston rod) |

* Specifications other than the above are the same as the standard basic type.
Note 1) Excluding the air-hydro type and the type with a rod boot of the CA2 series.
Note 2) Combination of auto switches and steel tube is not available.
For details, refer to page 1125.

Dimensions

* The dimensions are the same as the standard double acting, single rod type. Refer to page 475 for details.

Cylinder with Stable Lubrication Function (Lube-retainer)

| | | | | | | | | |
|------|---------------------------------------|-----------|----------|--------|---|---|-----------------|--|
| CDA2 | Mounting type | Bore size | M | Stroke | Z | Pivot bracket | Rod end bracket | Auto switch |
| | With auto switch (Built-in magnet) | | | | | | | * D: Available only for with auto switch. |
| | | | | | | Cylinder with Stable Lubrication Function (Lube-retainer) | | |



Specifications

| | |
|----------------------------|----------------------------|
| Bore size (mm) | 40, 50, 63, 80, 100 |
| Action | Double acting, Single rod |
| Minimum operating pressure | 0.1 MPa |
| Piston speed | 50 to 500 mm/s |
| Cushion | Air cushion |

* Specifications other than the above are the same as the standard type.

Dimensions (Dimensions other than those shown below are the same as the standard type.)

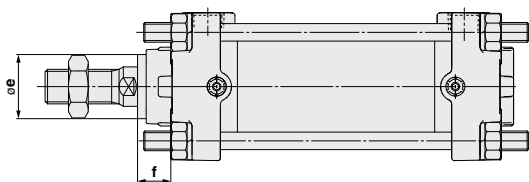

| Bore size | oe | f |
|------------|----|------|
| 40 | 26 | 13.5 |
| 50 | 30 | 12.5 |
| 63 | 30 | 12.5 |
| 80 | 36 | 16.5 |
| 100 | 42 | 16 |

* The mounting dimensions of the mounting bracket are the same as the standard type.

For details, refer to the **Web Catalog**.

CJ1

CJP

CJ2

JCM

CM2

CM3

CG1

CG3

JMB

MB

MB1

CA2

CS1

CS2

D-□

-X□

Technical
Data

CA2 Series

Construction

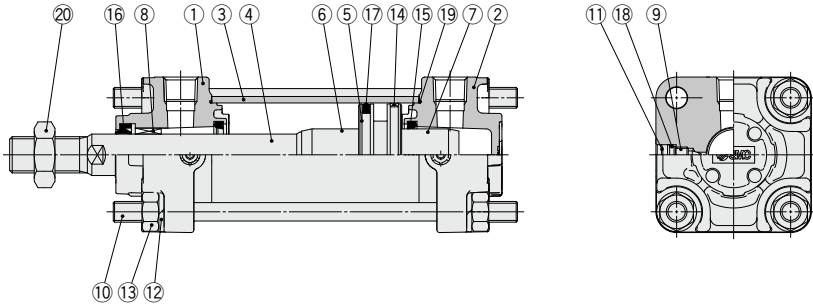

Component Parts

| No. | Description | Material | Note |
|-----|----------------------|---------------------|--------------------------|
| 1 | Rod cover | Aluminum die-casted | Trivalent chromated |
| 2 | Head cover | Aluminum die-casted | Trivalent chromated |
| 3 | Cylinder tube | Aluminum alloy | Hard anodized |
| 4 | Piston rod | Carbon steel | Hard chrome plating |
| 5 | Piston | Aluminum alloy | |
| 6 | Cushion ring | Aluminum alloy | Anodized |
| 7 | Cushion ring B | Aluminum alloy | Anodized |
| 8 | Bushing | Bearing alloy | |
| 9 | Cushion valve | Steel wire | Trivalent zinc chromated |
| 10 | Tie-rod | Carbon steel | Trivalent zinc chromated |
| 11 | Retaining ring | Spring steel | Phosphate coating |
| 12 | Spring washer | Steel wire | Trivalent zinc chromated |
| 13 | Tie-rod nut | Rolled steel | Trivalent zinc chromated |
| 14 | Wear ring | Resin | |
| 15 | Cushion seal | Urethane | |
| 16 | Rod seal | NBR | |
| 17 | Piston seal | NBR | |
| 18 | Cushion valve seal | NBR | |
| 19 | Cylinder tube gasket | NBR | |
| 20 | Rod end nut | Rolled steel | Trivalent zinc chromated |

Replacement Parts: Seal Kit

| Bore size (mm) | Kit no. | Contents |
|----------------|-------------|-----------------------------------|
| 40 | CA2-40Z-PS | Set of the nos. 15, 16, 17, 19 |
| 50 | CA2-50Z-PS | |
| 63 | CA2-63Z-PS | |
| 80 | CA2-80Z-PS | |
| 100 | CA2-100Z-PS | |

- * Seal kit includes 15, 16, 17, 19. Order the seal kit based on each bore size.
- * Do not disassemble the trunnion type. Refer to page 525.
- * Seal kit includes a grease pack (ø40, ø50: 10 g, ø63, ø80: 20 g, ø100: 30 g). Order with the following part number when only the grease pack is needed.
Grease pack part number: GR-S-010 (10 g), GR-S-020 (20 g)

Basic: CA2B

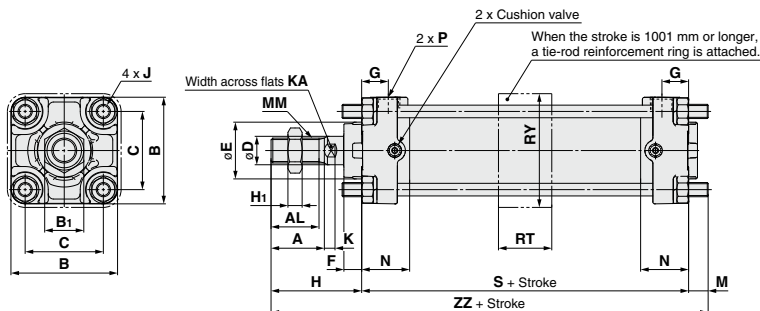

With rod boot

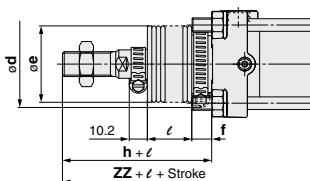

- CAJ1
- CJP
- CJ2
- JCM
- CM2
- CM3
- CG1
- CG3
- JMB
- MB
- MB1
- CA2**
- CS1
- CS2

| Bore size (mm) | A | AL | B | B ₁ | C | D | E | F | G | H ₁ | J | K | KA | M | | MM | |
|----------------|----|----|-----|----------------|----|----|----|----|----|----------------|------------|----|----|---|----------------------------|----|-------------------------|
| | | | | | | | | | | | | | | | Without reinforcement ring | | With reinforcement ring |
| 40 | 30 | 27 | 60 | 22 | 44 | 16 | 32 | 10 | 15 | 8 | M8 x 1.25 | 6 | 14 | | 11 | 11 | M14 x 1.5 |
| 50 | 35 | 32 | 70 | 27 | 52 | 20 | 40 | 10 | 17 | 11 | M8 x 1.25 | 7 | 18 | | 11 | 12 | M18 x 1.5 |
| 63 | 35 | 32 | 85 | 27 | 64 | 20 | 40 | 10 | 17 | 11 | M10 x 1.25 | 7 | 18 | | 14 | 15 | M18 x 1.5 |
| 80 | 40 | 37 | 102 | 32 | 78 | 25 | 52 | 14 | 21 | 13 | M12 x 1.75 | 10 | 22 | | 17 | 19 | M22 x 1.5 |
| 100 | 40 | 37 | 116 | 41 | 92 | 30 | 52 | 14 | 21 | 16 | M12 x 1.75 | 10 | 26 | | 17 | 19 | M26 x 1.5 |

| Bore size (mm) | N | P | RT | RY | S | Without rod boot | | | | With rod boot | | | | | |
|----------------|----|-----|----|-----|-----|------------------|----------------------------|-------------------------|----|---------------|------|----|------------|----------------------------|-------------------------|
| | | | | | | H | ZZ | | d | e | f | h | l | ZZ | |
| | | | | | | | Without reinforcement ring | With reinforcement ring | | | | | | Without reinforcement ring | With reinforcement ring |
| 40 | 27 | 1/4 | 30 | 64 | 84 | 51 | 146 | 146 | 56 | 43 | 11.2 | 59 | 1/4 stroke | 154 | 154 |
| 50 | 30 | 3/8 | 30 | 76 | 90 | 58 | 159 | 160 | 64 | 52 | 11.2 | 66 | 1/4 stroke | 167 | 168 |
| 63 | 31 | 3/8 | 40 | 92 | 98 | 58 | 170 | 171 | 64 | 52 | 11.2 | 66 | 1/4 stroke | 178 | 179 |
| 80 | 37 | 1/2 | 45 | 112 | 116 | 71 | 204 | 206 | 76 | 65 | 12.5 | 80 | 1/4 stroke | 213 | 215 |
| 100 | 40 | 1/2 | 50 | 136 | 126 | 72 | 215 | 217 | 76 | 65 | 14 | 81 | 1/4 stroke | 224 | 226 |

Note 1) When a flange bracket is mounted on the head cover side of the basic type with bore size of ø50 to ø100 and stroke of 1001 mm or more, it is necessary to loosen the tie-rod to adjust the M dimension. When head flange type is ordered, adjustment is not necessary.

Note 2) For models with bore size of ø50 to ø100 and stroke of 1001 mm or more, do not mount a flange bracket on the rod cover side of the basic type since H dimension is different from those shown above. When rod flange type is used, order with the part number with bracket.

- D-□
- X□
- Technical Data

CA2 Series

Axial Foot: CA2L

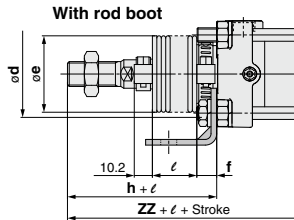
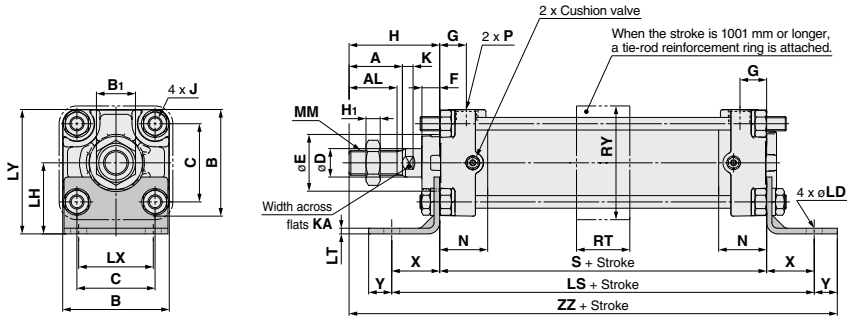

(mm)

| Bore size (mm) | A | AL | B | B_1 | C | D | E | F | G | H_1 | J | K | KA | LD | LH | LS | LT | LX | LY |
|----------------|----|----|-----|-------|----|----|----|----|----|-------|------------|----|----|------|----|-----|-----|----|-----|
| 40 | 30 | 27 | 60 | 22 | 44 | 16 | 32 | 10 | 15 | 8 | M8 x 1.25 | 6 | 14 | 9 | 40 | 138 | 3.2 | 42 | 70 |
| 50 | 35 | 32 | 70 | 27 | 52 | 20 | 40 | 10 | 17 | 11 | M8 x 1.25 | 7 | 18 | 9 | 45 | 144 | 3.2 | 50 | 80 |
| 63 | 35 | 32 | 85 | 27 | 64 | 20 | 40 | 10 | 17 | 11 | M10 x 1.25 | 7 | 18 | 11.5 | 50 | 166 | 3.2 | 59 | 93 |
| 80 | 40 | 37 | 102 | 32 | 78 | 25 | 52 | 14 | 21 | 13 | M12 x 1.75 | 10 | 22 | 13.5 | 65 | 204 | 4.5 | 76 | 116 |
| 100 | 40 | 37 | 116 | 41 | 92 | 30 | 52 | 14 | 21 | 16 | M12 x 1.75 | 10 | 26 | 13.5 | 75 | 212 | 6 | 92 | 133 |

| Bore size (mm) | MM | N | P | S | X | Y | RT | RY | Without rod boot | | With rod boot | | | | | |
|----------------|-----------|----|-----|-----|----|----|----|-----|------------------|-----|---------------|----|------|----|------------|-----|
| | | | | | | | | | H | ZZ | d | e | f | h | ℓ | ZZ |
| 40 | M14 x 1.5 | 27 | 1/4 | 84 | 27 | 13 | 30 | 64 | 51 | 175 | 56 | 43 | 11.2 | 59 | 1/4 stroke | 183 |
| 50 | M18 x 1.5 | 30 | 3/8 | 90 | 27 | 13 | 30 | 76 | 58 | 188 | 64 | 52 | 11.2 | 66 | 1/4 stroke | 196 |
| 63 | M18 x 1.5 | 31 | 3/8 | 98 | 34 | 16 | 40 | 92 | 58 | 206 | 64 | 52 | 11.2 | 66 | 1/4 stroke | 214 |
| 80 | M22 x 1.5 | 37 | 1/2 | 116 | 44 | 16 | 45 | 112 | 71 | 247 | 76 | 65 | 12.5 | 80 | 1/4 stroke | 256 |
| 100 | M26 x 1.5 | 40 | 1/2 | 126 | 43 | 17 | 50 | 136 | 72 | 258 | 76 | 65 | 14.0 | 81 | 1/4 stroke | 267 |

Rod Flange: CA2F

Stroke of 1000 mm or less

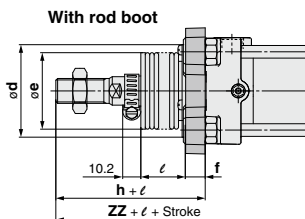
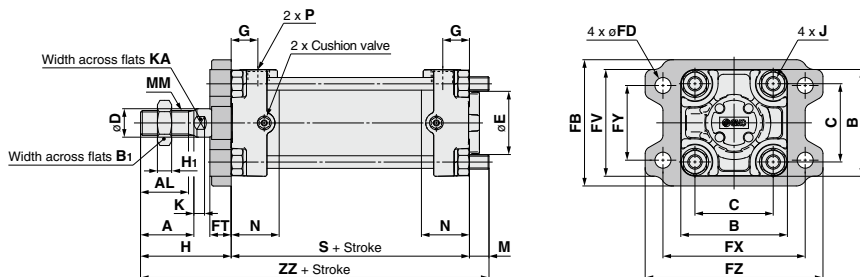

- CJ1
- CJP
- CJ2
- JCM
- CM2
- CM3
- CG1
- CG3
- JMB
- MB
- MB1
- CA2
- CS1
- CS2

| Bore size (mm) | A | AL | B | B ₁ | C | D | E | FB | FD | FT | FV | FX | FY | FZ | G | H ₁ | J | K | KA |
|----------------|----|----|-----|----------------|----|----|----|-----|------|----|-----|-----|----|-----|-----|----------------|------------|-----------|----|
| | 40 | 30 | 27 | 60 | 22 | 44 | 16 | 32 | 71 | 9 | 12 | 60 | 80 | 42 | 100 | 15 | 8 | M8 x 1.25 | 6 |
| 50 | 35 | 32 | 70 | 27 | 52 | 20 | 40 | 81 | 9 | 12 | 70 | 90 | 50 | 110 | 17 | 11 | M8 x 1.25 | 7 | 18 |
| 63 | 35 | 32 | 85 | 27 | 64 | 20 | 40 | 101 | 11.5 | 15 | 86 | 105 | 59 | 130 | 17 | 11 | M10 x 1.25 | 7 | 18 |
| 80 | 40 | 37 | 102 | 32 | 78 | 25 | 52 | 119 | 13.5 | 18 | 102 | 130 | 76 | 160 | 21 | 13 | M12 x 1.75 | 10 | 22 |
| 100 | 40 | 37 | 116 | 41 | 92 | 30 | 52 | 133 | 13.5 | 18 | 116 | 150 | 92 | 180 | 21 | 16 | M12 x 1.75 | 10 | 26 |

| Bore size (mm) | M | MM | N | P | S | Without rod boot | | With rod boot | | | | | |
|----------------|----|-----------|----|-----|-----|------------------|-----|---------------|----|------|----|------------|-----|
| | | | | | | H | ZZ | *d | e | f | h | ℓ | ZZ |
| | | | | | | 40 | 11 | M14 x 1.5 | 27 | 1/4 | 84 | 51 | 146 |
| 50 | 11 | M18 x 1.5 | 30 | 3/8 | 90 | 58 | 159 | 58 | 52 | 15 | 66 | 1/4 stroke | 167 |
| 63 | 14 | M18 x 1.5 | 31 | 3/8 | 98 | 58 | 170 | 58 | 52 | 17.5 | 66 | 1/4 stroke | 178 |
| 80 | 17 | M22 x 1.5 | 37 | 1/2 | 116 | 71 | 204 | 80 | 65 | 21.5 | 80 | 1/4 stroke | 213 |
| 100 | 17 | M26 x 1.5 | 40 | 1/2 | 126 | 72 | 215 | 80 | 65 | 21.5 | 81 | 1/4 stroke | 224 |

(mm)

★For installing an air cylinder, when a hole must be made to accommodate the rod portion, make sure to machine a hole that is larger than the outer diameter of the boot mounting bracket ød.

- D-□
- -X□
- Technical Data

CA2 Series

Rod Flange: CA2F

Stroke of 1001 mm or more

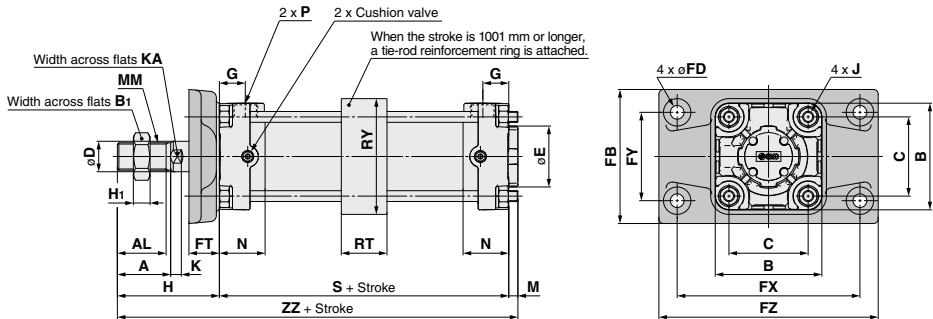

With rod boot

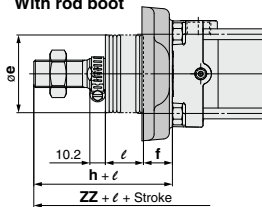

| Bore size (mm) | A | AL | B | B ₁ | C | D | E | FB | FD | FT | FX | FY | FZ | G | H ₁ | J | K | KA | M |
|----------------|----|----|-----|----------------|----|----|----|-----|------|----|-----|-----|-----|----|----------------|------------|----|----|----|
| 40 | 30 | 27 | 60 | 22 | 44 | 16 | 32 | 71 | 9 | 12 | 80 | 42 | 100 | 15 | 8 | M8 x 1.25 | 6 | 14 | 11 |
| 50 | 35 | 32 | 70 | 27 | 52 | 20 | 40 | 88 | 9 | 20 | 120 | 58 | 144 | 17 | 11 | M8 x 1.25 | 7 | 18 | 6 |
| 63 | 35 | 32 | 85 | 27 | 64 | 20 | 40 | 105 | 11.5 | 23 | 140 | 64 | 170 | 17 | 11 | M10 x 1.25 | 7 | 18 | 10 |
| 80 | 40 | 37 | 102 | 32 | 78 | 25 | 52 | 124 | 13.5 | 28 | 164 | 84 | 198 | 21 | 13 | M12 x 1.75 | 10 | 22 | 12 |
| 100 | 40 | 37 | 116 | 41 | 92 | 30 | 52 | 140 | 13.5 | 29 | 180 | 100 | 220 | 21 | 16 | M12 x 1.75 | 10 | 26 | 12 |

| Bore size (mm) | MM | N | P | RT | RY | S | Without rod boot | | | | With rod boot | | | |
|----------------|-----------|----|-----|----|-----|-----|------------------|-----|----|----|---------------|------------|-----|--|
| | | | | | | | H | ZZ | *e | f | h | ℓ | ZZ | |
| 40 | M14 x 1.5 | 27 | 1/4 | 30 | 64 | 84 | 51 | 146 | 52 | 19 | 66 | 1/4 stroke | 162 | |
| 50 | M18 x 1.5 | 30 | 3/8 | 30 | 76 | 90 | 67 | 163 | 52 | 19 | 66 | 1/4 stroke | 162 | |
| 63 | M18 x 1.5 | 31 | 3/8 | 40 | 92 | 98 | 71 | 179 | 52 | 19 | 66 | 1/4 stroke | 174 | |
| 80 | M22 x 1.5 | 37 | 1/2 | 45 | 112 | 116 | 87 | 215 | 65 | 21 | 80 | 1/4 stroke | 208 | |
| 100 | M26 x 1.5 | 40 | 1/2 | 50 | 136 | 126 | 89 | 227 | 65 | 21 | 81 | 1/4 stroke | 219 | |

★For installing an air cylinder, when a hole must be made to accommodate the rod portion, make sure to machine a hole that is larger than the outer diameter of the boot ϕ .

Note 1) For flange type with bore size of $\phi 40$, the same flange bracket is used for all strokes.

Note 2) For models with bore size of $\phi 50$ to $\phi 100$ and stroke of 1001 mm or more, do not mount a flange bracket on the rod cover side of the basic type since H dimension is different from those shown above. When rod flange type is used, order with the part number with bracket.

Head Flange: CA2G

Stroke of 1000 mm or less

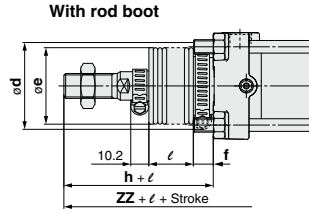
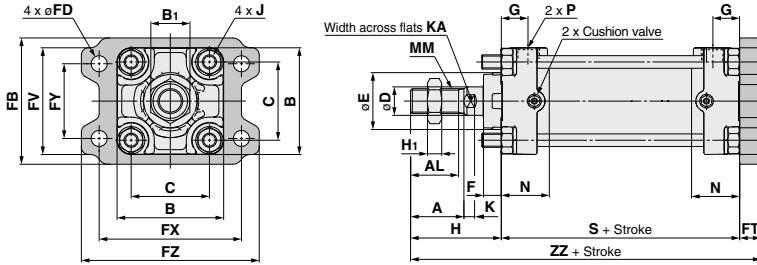

- CAJ1
- CJP
- CJ2
- JCM
- CM2
- CM3
- CG1
- CG3
- JMB
- MB
- MB1
- CA2**
- CS1
- CS2

| Bore size (mm) | A | AL | B | B ₁ | C | D | E | F | FB | FD | FT | FV | FX | FY | FZ | G | H ₁ | J |
|----------------|----|----|-----|----------------|----|----|----|----|-----|------|----|-----|-----|----|-----|----|----------------|------------|
| 40 | 30 | 27 | 60 | 22 | 44 | 16 | 32 | 10 | 71 | 9 | 12 | 60 | 80 | 42 | 100 | 15 | 8 | M8 x 1.25 |
| 50 | 35 | 32 | 70 | 27 | 52 | 20 | 40 | 10 | 81 | 9 | 12 | 70 | 90 | 50 | 110 | 17 | 11 | M8 x 1.25 |
| 63 | 35 | 32 | 85 | 27 | 64 | 20 | 40 | 10 | 101 | 11.5 | 15 | 86 | 105 | 59 | 130 | 17 | 11 | M10 x 1.25 |
| 80 | 40 | 37 | 102 | 32 | 78 | 25 | 52 | 14 | 119 | 13.5 | 18 | 102 | 130 | 76 | 160 | 21 | 13 | M12 x 1.75 |
| 100 | 40 | 37 | 116 | 41 | 92 | 30 | 52 | 14 | 133 | 13.5 | 18 | 116 | 150 | 92 | 180 | 21 | 16 | M12 x 1.75 |

| Bore size (mm) | K | KA | MM | N | P | S | Without rod boot | | With rod boot | | | | | |
|----------------|----|----|-----------|----|-----|-----|------------------|-----|---------------|----|------|----|------------|-----|
| | | | | | | | H | ZZ | d | e | f | h | ℓ | ZZ |
| 40 | 6 | 14 | M14 x 1.5 | 27 | 1/4 | 84 | 51 | 147 | 56 | 43 | 11.2 | 59 | 1/4 stroke | 155 |
| 50 | 7 | 18 | M18 x 1.5 | 30 | 3/8 | 90 | 58 | 160 | 64 | 52 | 11.2 | 66 | 1/4 stroke | 168 |
| 63 | 7 | 18 | M18 x 1.5 | 31 | 3/8 | 98 | 58 | 171 | 64 | 52 | 11.2 | 66 | 1/4 stroke | 179 |
| 80 | 10 | 22 | M22 x 1.5 | 37 | 1/2 | 116 | 71 | 205 | 76 | 65 | 12.5 | 80 | 1/4 stroke | 214 |
| 100 | 10 | 26 | M26 x 1.5 | 40 | 1/2 | 126 | 72 | 216 | 76 | 65 | 14.0 | 81 | 1/4 stroke | 225 |

- D-□
- X□
- Technical Data

CA2 Series

Head Flange: CA2G

Stroke of 1001 mm or more

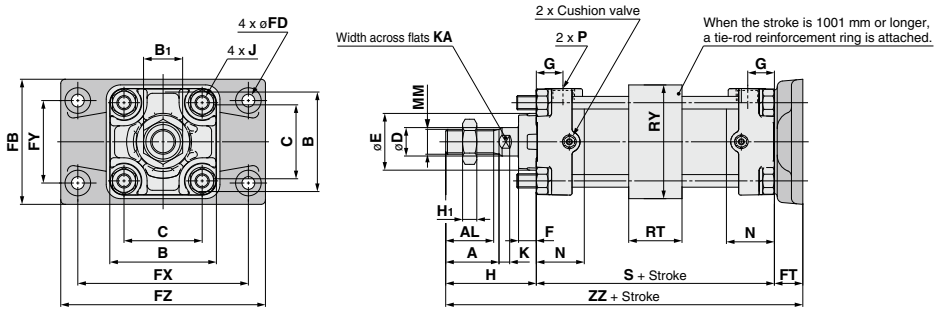

With rod boot

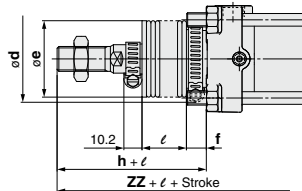

| Bore size (mm) | A | AL | B | B ₁ | C | D | E | FB | FD | FT | FX | FY | FZ | G | H ₁ | J | K | KA |
|----------------|----|----|-----|----------------|----|----|----|-----|------|----|-----|-----|-----|-----|----------------|------------|-----------|----|
| | 40 | 30 | 27 | 60 | 22 | 44 | 16 | 30 | 71 | 9 | 12 | 80 | 42 | 100 | 15 | 8 | M8 x 1.25 | 6 |
| 50 | 35 | 32 | 70 | 27 | 52 | 20 | 40 | 88 | 9 | 20 | 120 | 58 | 144 | 17 | 11 | M8 x 1.25 | 7 | 18 |
| 63 | 35 | 32 | 85 | 27 | 64 | 20 | 40 | 105 | 11.5 | 23 | 140 | 64 | 170 | 17 | 11 | M10 x 1.25 | 7 | 18 |
| 80 | 40 | 37 | 102 | 32 | 78 | 25 | 52 | 124 | 13.5 | 28 | 164 | 84 | 198 | 21 | 13 | M12 x 1.75 | 10 | 22 |
| 100 | 40 | 37 | 116 | 41 | 92 | 30 | 52 | 140 | 13.5 | 29 | 180 | 100 | 220 | 21 | 16 | M12 x 1.75 | 10 | 26 |

| Bore size (mm) | MM | N | P | S | RT | RY | Without rod boot | | With rod boot | | | | | |
|----------------|-----------|----|-----|-----|----|-----|------------------|-----|---------------|----|------|----|------------|-----|
| | | | | | | | H | ZZ | d | e | f | h | ℓ | ZZ |
| 40 | M14 x 1.5 | 27 | 1/4 | 84 | 30 | 64 | 51 | 147 | 56 | 43 | 11.2 | 59 | 1/4 stroke | 155 |
| 50 | M18 x 1.5 | 30 | 3/8 | 90 | 30 | 76 | 58 | 168 | 64 | 52 | 11.2 | 66 | 1/4 stroke | 176 |
| 63 | M18 x 1.5 | 31 | 3/8 | 98 | 40 | 92 | 58 | 179 | 64 | 52 | 11.2 | 66 | 1/4 stroke | 187 |
| 80 | M22 x 1.5 | 37 | 1/2 | 116 | 45 | 112 | 71 | 215 | 76 | 65 | 12.5 | 80 | 1/4 stroke | 224 |
| 100 | M26 x 1.5 | 40 | 1/2 | 126 | 50 | 136 | 72 | 227 | 76 | 65 | 14 | 81 | 1/4 stroke | 236 |

Note 1) For flange type with bore size of ø40, the same flange bracket is used for all strokes.

Note 2) When a flange bracket is mounted on the head cover side of the basic type with bore size of ø50 to ø100 and stroke of 1001 mm or more, it is necessary to loosen the tie-rod to adjust the M dimension. When head flange type is ordered, adjustment is not necessary.

Single Clevis: CA2C

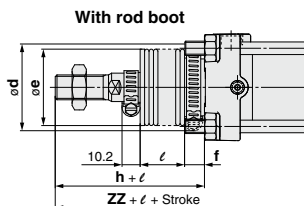
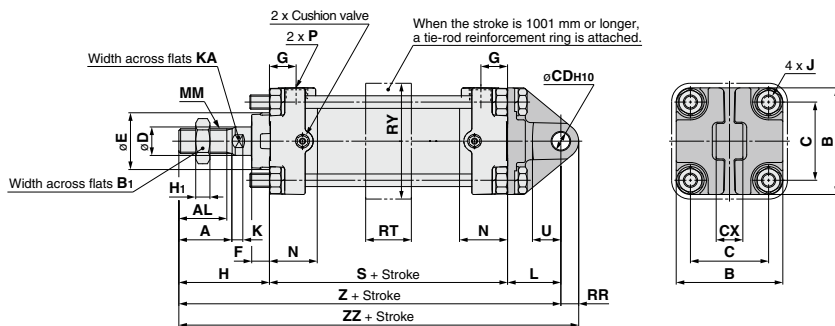

- CJ1
- CJP
- CJ2
- JCM
- GM2
- CM3
- CG1
- CG3
- JMB
- MB
- MB1
- CA2**
- CS1
- CS2

| Bore size (mm) | A | AL | B | B ₁ | C | CD _{H10} | CX | D | E | F | G | H ₁ | J | K | KA | L |
|----------------|----|----|-----|----------------|----|-----------------------------------|--------------------------------------|----|----|----|----|----------------|------------|----|----|----|
| 40 | 30 | 27 | 60 | 22 | 44 | 10 ^{+0.058} ₀ | 15 ^{-0.1} _{-0.3} | 16 | 32 | 10 | 15 | 8 | M8 x 1.25 | 6 | 14 | 30 |
| 50 | 35 | 32 | 70 | 27 | 52 | 12 ^{+0.070} ₀ | 18 ^{-0.1} _{-0.3} | 20 | 40 | 10 | 17 | 11 | M8 x 1.25 | 7 | 18 | 35 |
| 63 | 35 | 32 | 85 | 27 | 64 | 16 ^{+0.070} ₀ | 25 ^{-0.1} _{-0.3} | 20 | 40 | 10 | 17 | 11 | M10 x 1.25 | 7 | 18 | 40 |
| 80 | 40 | 37 | 102 | 32 | 78 | 20 ^{+0.084} ₀ | 31.5 ^{-0.1} _{-0.3} | 25 | 52 | 14 | 21 | 13 | M12 x 1.75 | 10 | 22 | 48 |
| 100 | 40 | 37 | 116 | 41 | 92 | 25 ^{+0.084} ₀ | 35.5 ^{-0.1} _{-0.3} | 30 | 52 | 14 | 21 | 16 | M12 x 1.75 | 10 | 26 | 58 |

| Bore size (mm) | MM | N | P | RR | S | U | Without rod boot | | | With rod boot | | | | | | |
|----------------|-----------|----|-----|----|-----|----|------------------|-----|-----|---------------|----|------|----|------------|-----|-----|
| | | | | | | | H | Z | ZZ | d | e | f | h | ℓ | Z | ZZ |
| 40 | M14 x 1.5 | 27 | 1/4 | 10 | 84 | 16 | 51 | 165 | 175 | 56 | 43 | 11.2 | 59 | 1/4 stroke | 173 | 183 |
| 50 | M18 x 1.5 | 30 | 3/8 | 12 | 90 | 19 | 58 | 183 | 195 | 64 | 52 | 11.2 | 66 | 1/4 stroke | 191 | 203 |
| 63 | M18 x 1.5 | 31 | 3/8 | 16 | 98 | 23 | 58 | 196 | 212 | 64 | 52 | 11.2 | 66 | 1/4 stroke | 204 | 220 |
| 80 | M22 x 1.5 | 37 | 1/2 | 20 | 116 | 28 | 71 | 235 | 255 | 76 | 65 | 12.5 | 80 | 1/4 stroke | 244 | 264 |
| 100 | M26 x 1.5 | 40 | 1/2 | 25 | 126 | 36 | 72 | 256 | 281 | 76 | 65 | 14.0 | 81 | 1/4 stroke | 265 | 290 |

- D-□
- X□
- Technical Data

CA2 Series

Double Clevis: CA2D

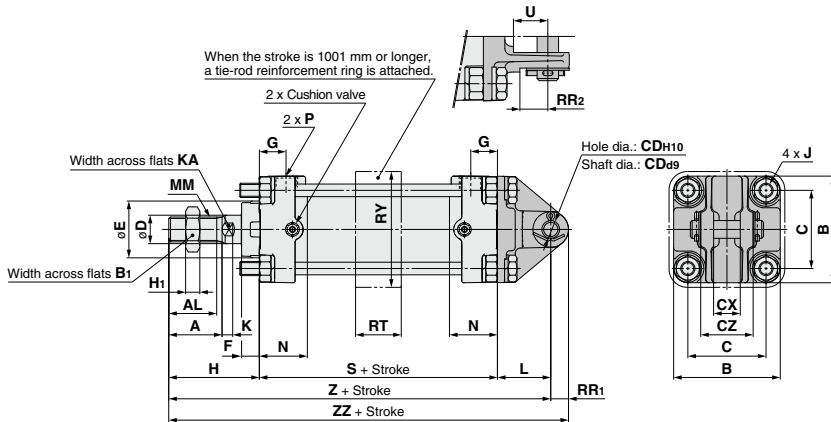

With rod boot

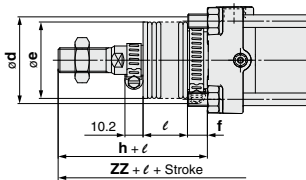

| Bore size (mm) | | | | | | | | | | | | | | | (mm) | | |
|----------------|----|----|-----|----------------|----|-----------------------------------|--------------------------------------|------|----|----|----|----|----------------|------------|------|----|----|
| | A | AL | B | B ₁ | C | CD _{H10} | CX | CZ | D | E | F | G | H ₁ | J | K | KA | L |
| 40 | 30 | 27 | 60 | 22 | 44 | 10 ^{+0.058} ₀ | 15 ^{+0.3} _{-0.1} | 29.5 | 16 | 32 | 10 | 15 | 8 | M8 x 1.25 | 6 | 14 | 30 |
| 50 | 35 | 32 | 70 | 27 | 52 | 12 ^{+0.070} ₀ | 18 ^{+0.3} _{-0.1} | 38 | 20 | 40 | 10 | 17 | 11 | M8 x 1.25 | 7 | 18 | 35 |
| 63 | 35 | 32 | 85 | 27 | 64 | 16 ^{+0.070} ₀ | 25 ^{+0.3} _{-0.1} | 49 | 20 | 40 | 10 | 17 | 11 | M10 x 1.25 | 7 | 18 | 40 |
| 80 | 40 | 37 | 102 | 32 | 78 | 20 ^{+0.084} ₀ | 31.5 ^{+0.3} _{-0.1} | 61 | 25 | 52 | 14 | 21 | 13 | M12 x 1.75 | 10 | 22 | 48 |
| 100 | 40 | 37 | 116 | 41 | 92 | 25 ^{+0.084} ₀ | 35.5 ^{+0.3} _{-0.1} | 64 | 30 | 52 | 14 | 21 | 16 | M12 x 1.75 | 10 | 26 | 58 |

| Bore size (mm) | MM | N | P | RR ₁ | RR ₂ | S | U | Without rod boot | | | With rod boot | | | | | | |
|----------------|-----------|----|-----|-----------------|-----------------|-----|----|------------------|-----|-----|---------------|----|------|----|------------|-----|-----|
| | | | | | | | | H | Z | ZZ | d | e | f | h | ℓ | Z | ZZ |
| 40 | M14 x 1.5 | 27 | 1/4 | 10 | 16 | 84 | 16 | 51 | 165 | 175 | 56 | 43 | 11.2 | 59 | 1/4 stroke | 173 | 183 |
| 50 | M18 x 1.5 | 30 | 3/8 | 12 | 19 | 90 | 19 | 58 | 183 | 195 | 64 | 52 | 11.2 | 66 | 1/4 stroke | 191 | 203 |
| 63 | M18 x 1.5 | 31 | 3/8 | 16 | 23 | 98 | 23 | 58 | 196 | 212 | 64 | 52 | 11.2 | 66 | 1/4 stroke | 204 | 220 |
| 80 | M22 x 1.5 | 37 | 1/2 | 20 | 28 | 116 | 28 | 71 | 235 | 255 | 76 | 65 | 12.5 | 80 | 1/4 stroke | 244 | 264 |
| 100 | M26 x 1.5 | 40 | 1/2 | 25 | 23.5 | 126 | 36 | 72 | 256 | 281 | 76 | 65 | 14.0 | 81 | 1/4 stroke | 265 | 290 |

* A clevis pin, flat washers and split pins are included.

Center Trunnion: CA2T

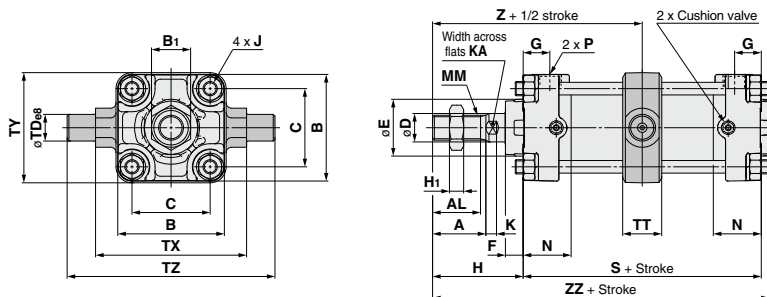

With rod boot

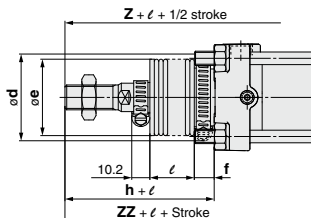

- CJ1
- CJP
- CJ2
- JCM
- CM2
- CM3
- CG1
- CG3
- JMB
- MB
- MB1
- CA2**
- CS1
- CS2

| Bore size (mm) | | | | | | | | | | | | | | | | | (mm) | |
|----------------|----|----|-----|----------------|----|----|----|----|----|----------------|------------|----|----|-----------|----|-----|------|--|
| | A | AL | B | B ₁ | C | D | E | F | G | H ₁ | J | K | KA | MM | N | P | S | |
| 40 | 30 | 27 | 60 | 22 | 44 | 16 | 32 | 10 | 15 | 8 | M8 x 1.25 | 6 | 14 | M14 x 1.5 | 27 | 1/4 | 84 | |
| 50 | 35 | 32 | 70 | 27 | 52 | 20 | 40 | 10 | 17 | 11 | M8 x 1.25 | 7 | 18 | M18 x 1.5 | 30 | 3/8 | 90 | |
| 63 | 35 | 32 | 85 | 27 | 64 | 20 | 40 | 10 | 17 | 11 | M10 x 1.25 | 7 | 18 | M18 x 1.5 | 31 | 3/8 | 98 | |
| 80 | 40 | 37 | 102 | 32 | 78 | 25 | 52 | 14 | 21 | 13 | M12 x 1.75 | 10 | 22 | M22 x 1.5 | 37 | 1/2 | 116 | |
| 100 | 40 | 37 | 116 | 41 | 92 | 30 | 52 | 14 | 21 | 16 | M12 x 1.75 | 10 | 26 | M26 x 1.5 | 40 | 1/2 | 126 | |

| Bore size (mm) | TD _{es} | TT | TX | TY | TZ | Without rod boot | | | With rod boot | | | | | | |
|----------------|--|----|-----|-----|-----|------------------|-----|-----|---------------|----|------|----|------------|-----|-----|
| | | | | | | H | Z | ZZ | d | e | f | h | ℓ | Z | ZZ |
| 40 | 15 ^{-0.032} _{-0.059} | 22 | 85 | 62 | 117 | 51 | 93 | 140 | 56 | 43 | 11.2 | 59 | 1/4 stroke | 101 | 148 |
| 50 | 15 ^{-0.032} _{-0.059} | 22 | 95 | 74 | 127 | 58 | 103 | 154 | 64 | 52 | 11.2 | 66 | 1/4 stroke | 111 | 162 |
| 63 | 16 ^{-0.048} _{-0.059} | 28 | 110 | 90 | 148 | 58 | 107 | 162 | 64 | 52 | 11.2 | 66 | 1/4 stroke | 115 | 170 |
| 80 | 25 ^{-0.040} _{-0.073} | 34 | 140 | 110 | 192 | 71 | 129 | 194 | 76 | 65 | 12.5 | 80 | 1/4 stroke | 138 | 203 |
| 100 | 25 ^{-0.040} _{-0.073} | 40 | 162 | 130 | 214 | 72 | 135 | 206 | 76 | 65 | 14.0 | 81 | 1/4 stroke | 144 | 215 |

* Do not disassemble the trunnion type. Refer to page 525.

- D-□
- X□
- Technical Data

CA2 Series

Trunnion and Double Clevis Pivot Bracket

- Strength is the same as cylinder brackets.

Applicable Series

| Bracket type | Applicable series |
|-----------------------------|-------------------|
| Trunnion pivot bracket | CA2 |
| Double clevis pivot bracket | CA2 |

* Please contact SMC at the time of mounting.

| Bore size | CA2□40 | CA2□50 | CA2□63 | CA2□80 | CA2□100 |
|-----------------------------|---------|--------|---------|---------|---------|
| Description | CA2-S04 | | CA2-S06 | MB-S10 | |
| Trunnion pivot bracket | CA2-B04 | | CA2-B05 | CA2-B06 | CA2-B08 |
| Double clevis pivot bracket | CA2-B04 | | CA2-B05 | CA2-B06 | CA2-B08 |

* Order 2 trunnion pivot brackets per cylinder.

Trunnion pivot bracket

Material: Cast iron

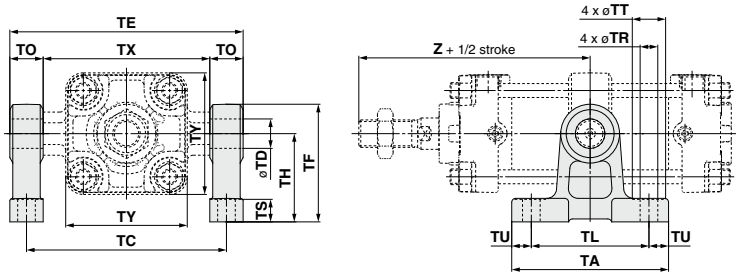

(mm)

| Part no. | Bore size (mm) | TA | TL | TU | TC | TX | TE | TO | TR | TT | TS | TH | TF | TY | Z | TD-H10 (Hole) |
|----------|----------------|-----|----|----|-----|-----|-----|----|------|----|----|----|-----|-----|-----|-----------------------------------|
| CA2-S04 | 40 | 80 | 60 | 10 | 102 | 85 | 119 | 17 | 9 | 17 | 12 | 45 | 60 | 62 | 93 | 15 ^{+0.070} ₀ |
| | 50 | 80 | 60 | 10 | 112 | 95 | 129 | 17 | 9 | 17 | 12 | 45 | 60 | 74 | 103 | 15 ^{+0.070} ₀ |
| CA2-S06 | 63 | 100 | 70 | 15 | 130 | 110 | 150 | 20 | 11 | 22 | 14 | 55 | 73 | 90 | 107 | 18 ^{+0.070} ₀ |
| | 80 | 120 | 90 | 15 | 166 | 140 | 192 | 26 | 13.5 | 24 | 17 | 75 | 100 | 110 | 129 | 25 ^{+0.084} ₀ |
| MB-S10 | 100 | 120 | 90 | 15 | 188 | 162 | 214 | 26 | 13.5 | 24 | 17 | 75 | 100 | 130 | 135 | 25 ^{+0.084} ₀ |

Double clevis pivot bracket

Material: Cast iron

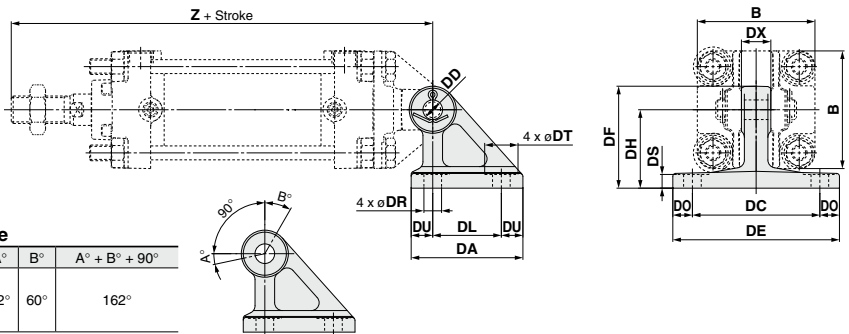

Rotating Angle

| Bore size (mm) | A° | B° | A° + B° + 90° |
|----------------|-----|-----|---------------|
| 40 to 100 | 12° | 60° | 162° |

(mm)

| Part no. | Bore size (mm) | DA | DL | DU | DC | DX | DE | DO | DR | DT | DS | DH | DF | B | Z | DDH10 (Hole) |
|----------|----------------|----|----|------|-----|------|-----|------|------|----|----|----|----|-----|-----|-----------------------------------|
| CA2-B04 | 40 | 57 | 35 | 11 | 65 | 15 | 85 | 10 | 9 | 17 | 8 | 40 | 52 | 60 | 165 | 10 ^{+0.058} ₀ |
| CA2-B05 | 50 | 57 | 35 | 11 | 65 | 18 | 85 | 10 | 9 | 17 | 8 | 40 | 52 | 70 | 183 | 12 ^{+0.070} ₀ |
| CA2-B06 | 63 | 67 | 40 | 13.5 | 80 | 25 | 105 | 12.5 | 11 | 22 | 10 | 50 | 66 | 85 | 196 | 16 ^{+0.070} ₀ |
| CA2-B08 | 80 | 93 | 60 | 16.5 | 100 | 31.5 | 130 | 15 | 13.5 | 24 | 12 | 65 | 90 | 102 | 235 | 20 ^{+0.084} ₀ |
| CA2-B10 | 100 | 93 | 60 | 16.5 | 100 | 35.5 | 130 | 15 | 13.5 | 24 | 12 | 65 | 90 | 116 | 256 | 25 ^{+0.084} ₀ |

CA2 Series Dimensions of Accessories

Y Type Double Knuckle Joint

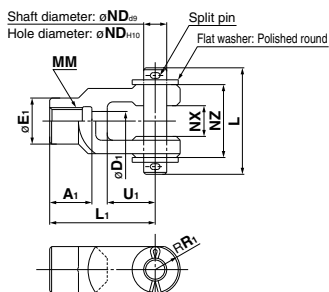

Material: Cast iron (mm)

| Part no. | Applicable bore size | | | | | | | | | | | Split pin size | Flat washer size | |
|----------|----------------------|----|----|----|----|-----------|----|----|----|--------------------------------------|----|----------------|------------------|-------------------|
| | | A1 | E1 | D1 | L1 | MM | R1 | U1 | ND | NX | NZ | | | L |
| Y-04D | 40 | 22 | 24 | 10 | 55 | M14 x 1.5 | 13 | 25 | 12 | 16 ^{+0.3} / _{+0.1} | 38 | 55.5 | ø3 x 18 L | Polished round 12 |
| Y-05D | 50, 63 | 27 | 28 | 14 | 60 | M18 x 1.5 | 15 | 27 | 12 | 16 ^{+0.3} / _{+0.1} | 38 | 55.5 | ø3 x 18 L | Polished round 12 |
| Y-08D | 80 | 37 | 36 | 18 | 71 | M22 x 1.5 | 19 | 28 | 18 | 26 ^{+0.3} / _{+0.1} | 55 | 76.5 | ø4 x 25 L | Polished round 18 |
| Y-10D | 100 | 37 | 40 | 21 | 83 | M26 x 1.5 | 21 | 38 | 20 | 30 ^{+0.3} / _{+0.1} | 61 | 83 | ø4 x 30 L | Polished round 20 |

* A knuckle pin, split pins and flat washers are included.

Clevis Pin/Knuckle Pin

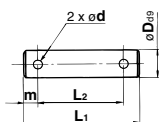

Material: Carbon steel (mm)

| Part no. | Applicable bore size | | Dd9 | L1 | L2 | m | d | Included split pin | Included flat washer |
|----------|----------------------|------------|--|------|------|---|---|--------------------|----------------------|
| | Clevis | Knuckle | | | | | | | |
| CDP-2A | 40 | — | 10 ^{-0.040} / _{-0.076} | 46 | 38 | 4 | 3 | ø3 x 18 L | Polished round 10 |
| CDP-3A | 50 | 40, 50, 63 | 12 ^{-0.050} / _{-0.093} | 55.5 | 47.5 | 4 | 3 | ø3 x 18 L | Polished round 12 |
| CDP-4A | 63 | — | 16 ^{-0.050} / _{-0.093} | 71 | 61 | 5 | 4 | ø4 x 25 L | Polished round 16 |
| CDP-5A | — | 80 | 18 ^{-0.050} / _{-0.093} | 76.5 | 66.5 | 5 | 4 | ø4 x 25 L | Polished round 18 |
| CDP-6A | 80 | 100 | 20 ^{-0.065} / _{-0.117} | 83 | 73 | 5 | 4 | ø4 x 30 L | Polished round 20 |
| CDP-7A | 100 | — | 25 ^{-0.065} / _{-0.117} | 88 | 78 | 5 | 4 | ø4 x 36 L | Polished round 24 |

* Split pins and flat washers are included.

I Type Single Knuckle Joint

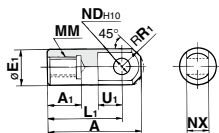

Material: Free cutting sulfur steel (mm)

| Part no. | Applicable bore size | | | | | | | | | | |
|----------|----------------------|-----|----|----|----|-----------|------|----|-------------------------------------|--------------------------------------|--|
| | | A | A1 | E1 | L1 | MM | R1 | U1 | ND _{H10} | NX | |
| I-04A | 40 | 69 | 22 | 24 | 55 | M14 x 1.5 | 15.5 | 20 | 12 ^{+0.070} / ₀ | 16 ^{-0.1} / _{-0.3} | |
| I-05A | 50, 63 | 74 | 27 | 28 | 60 | M18 x 1.5 | 15.5 | 20 | 12 ^{+0.070} / ₀ | 16 ^{-0.1} / _{-0.3} | |
| I-08A | 80 | 91 | 37 | 36 | 71 | M22 x 1.5 | 22.5 | 26 | 18 ^{+0.070} / ₀ | 28 ^{-0.1} / _{-0.3} | |
| I-10A | 100 | 105 | 37 | 40 | 83 | M26 x 1.5 | 24.5 | 28 | 20 ^{+0.084} / ₀ | 30 ^{-0.1} / _{-0.3} | |

Rod End Nut (Standard)

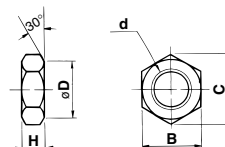

Material: Rolled steel (mm)

| Part no. | Applicable bore size | | | | | |
|----------|----------------------|-----------|----|----|------|----|
| | | d | H | B | C | D |
| NT-04 | 40 | M14 x 1.5 | 8 | 22 | 25.4 | 21 |
| NT-05 | 50, 63 | M18 x 1.5 | 11 | 27 | 31.2 | 26 |
| NT-08 | 80 | M22 x 1.5 | 13 | 32 | 37.0 | 31 |
| NT-10 | 100 | M26 x 1.5 | 16 | 41 | 47.3 | 39 |

CJ1

CJP

CJ2

JCM

CM2

CM3

CG1

CG3

JMB

MB

MB1

CA2

CS1

CS2

D-□

-X□

Technical Data

Air Cylinder: Standard Type Double Acting, Double Rod

CA2W Series

ø40, ø50, ø63, ø80, ø100

RoHS

How to Order

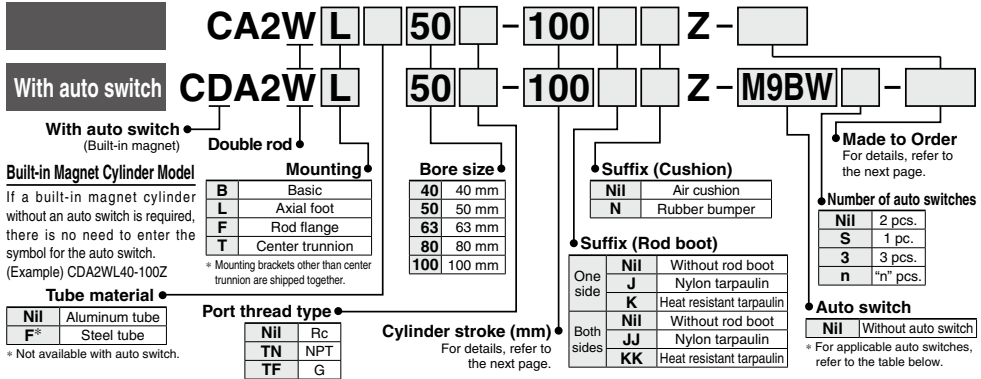

Applicable Auto Switches/Refer to pages 1575 to 1701 for further information on auto switches.

| Type | Special function | Electrical entry | Indication light | Wiring (Output) | Load voltage | | Auto switch model | | Lead wire length (m) | | | | | Pre-wired connector | Applicable load | | |
|-------------------------------------|--|---------------------|------------------|--|--------------|-----------|-------------------|---------------|----------------------|-------|--------|-------|------------|---------------------|-----------------|------------|---|
| | | | | | DC | AC | Tie-rod mounting | Band mounting | 0.5 (Nil) | 1 (M) | 3 (L) | 5 (Z) | IC circuit | | Relay, PLC | | |
| Solid state auto switch | — | Grommet | No | 3-wire (NPN) | 24 V | 5 V, 12 V | — | M9N | ● | ● | ○ | ○ | ○ | IC circuit | — | — | |
| | | | | 3-wire (PNP) | | | | M9P | ● | ● | ○ | ○ | ○ | | | | |
| | | | | 2-wire | M9B | ● | ● | ○ | ○ | ○ | | | | | | | |
| | | Terminal conduit | | 3-wire (NPN) | 12 V | G39C | G39 | — | — | — | — | | | | | | |
| | | | | 2-wire | | K39C | K39 | — | — | — | — | | | | | | |
| | | | | 3-wire (NPN) | M9NW | ● | ● | ○ | ○ | ○ | | | | | | | |
| | Diagnostic indication (2-color indicator) | Yes | Grommet | Yes | 3-wire (PNP) | 5 V, 12 V | — | — | G59W | ● | ● | ○ | ○ | ○ | IC circuit | Relay, PLC | |
| | | | | | 3-wire (PNP) | | | | M9PW | ● | ● | ○ | ○ | ○ | | | |
| | | | | | 2-wire | G5PW | ● | ● | ○ | ○ | ○ | | | | | | |
| | | Grommet | 2-wire | | 24 V | 12 V | — | — | — | M9BW | ● | ● | ○ | ○ | ○ | | |
| | | | 3-wire (NPN) | | | | | | | K59W | ● | ● | ○ | ○ | ○ | | |
| | | | 3-wire (PNP) | | M9NA*1 | — | ○ | ○ | ● | ○ | ○ | | | | | | |
| Water resistant (2-color indicator) | — | Grommet | No | 3-wire (PNP) | 5 V, 12 V | — | — | M9PA*1 | — | ○ | ○ | ● | ○ | ○ | — | — | |
| | | | | 2-wire | | | | M9BA*1 | — | ○ | ○ | ● | ○ | ○ | | | |
| | | | | With diagnostic output (2-color indicator) | 4-wire (NPN) | 12 V | — | — | — | — | G5BA*1 | — | — | — | — | | — |
| | 2-wire | F59F | | | G59F | | | | | | ● | — | ● | ○ | ○ | | ○ |
| | Magnetic field resistant (2-color indicator) | 2-wire (Non-polar) | | | 5 V, 12 V | — | — | — | — | P3DWA | — | — | — | — | — | | |
| | | 3-wire (NPN equiv.) | | P4DW | | | | | | — | — | — | — | — | | | |
| — | | A96 | — | — | — | — | — | | | | | | | | | | |
| Reed auto switch | — | Grommet | Yes | 3-wire (NPN equiv.) | 24 V | 12 V | — | A93 | — | — | ● | ● | ● | — | IC circuit | Relay, PLC | |
| | | | | | | | | A90 | — | — | ● | ● | ● | — | | | |
| | | | | | | | | A54 | B54 | — | — | ● | — | ● | | | — |
| | | | | | | | | A64 | B64 | — | — | ● | — | ● | | | — |
| | | | | | | | | A33C | A33 | — | — | — | — | — | | | — |
| | | Terminal conduit | | A34C | A34 | — | — | — | — | — | | | | | | | |
| | | | | DIN terminal | A44C | A44 | — | — | — | — | | | | | | | |
| | | | | | A59W | B59W | ● | — | ● | — | — | | | | | | |
| | | | | Grommet | — | — | — | — | — | — | — | | | | | | |
| | | | | | — | | | | | | | — | — | — | — | | |

*1 Water resistant type auto switches can be mounted on the above models, but in such case SMC cannot guarantee water resistance.

A water-resistant type cylinder is recommended for use in an environment which requires water resistance.

* Lead wire length symbols: 0.5 m.....Nil (Example) M9NW 3 m.....L (Example) M9NWL 1 m.....M (Example) M9NWM 5 m.....Z (Example) M9NWZ

* Solid state auto switches marked with "○" are produced upon receipt of order.

* Since there are other applicable auto switches than listed above, refer to page 523 for details.

* For details about auto switches with pre-wired connector, refer to pages 1648 and 1649.

* The D-A9□/M9□□□P3DWA□ auto switches are shipped together, (but not assembled). (However, auto switch mounting brackets are assembled for the D-A9□/M9□□ before shipment.)

Specifications

| Bore size (mm) | 40 | 50 | 63 | 80 | 100 |
|-------------------------------|--|----|----|----|-----|
| Fluid | Air | | | | |
| Action | Double acting | | | | |
| Proof pressure | 1.5 MPa | | | | |
| Maximum operating pressure | 1.0 MPa | | | | |
| Minimum operating pressure | 0.08 MPa | | | | |
| Piston speed | 50 to 500 mm/s | | | | |
| Ambient and fluid temperature | Without auto switch: -10 to 70°C* With auto switch : -10 to 60°C* | | | | |
| Cushion | Air cushion or Rubber bumper | | | | |
| Stroke length tolerance | Up to 250 st: $^{+1.0}_n$ 251 to 1000 st: $^{+1.4}_n$ | | | | |
| Lubrication | Not required (Non-lube) | | | | |
| Mounting | Basic, Axial foot, Rod flange, Center trunnion | | | | |

* No freezing

Standard Strokes

| Bore size | Standard stroke Note 1) | | Max. manufacturable stroke |
|-----------|---|----------------|----------------------------|
| | Stroke range ① | Stroke range ② | |
| 40 | 25, 50, 75, 100, 125, 150, 175, 200, 250, 300, 350, 400, 450, 500 | Up to 1000 | Up to 1800 |
| 50, 63 | 25, 50, 75, 100, 125, 150, 175, 200, 250, 300, 350, 400, 450, 500, 600 | Up to 1200 | |
| 80, 100 | 25, 50, 75, 100, 125, 150, 175, 200, 250, 300, 350, 400, 450, 500, 600, 700 | Up to 1500 | |

Note 1) Intermediate strokes not listed above are produced upon receipt of order.

Note 2) Applicable strokes should be confirmed according to the usage. For details, refer to "Air Cylinders Model Selection" on front matter pages. In addition, the products that exceed the stroke range ① might not be able to fulfill the specifications due to the deflection etc.

Note 3) Please consult with SMC for manufacturability and the part numbers when exceeding the stroke range ②.

Note 4) The stroke range with rod boot is 20 to 1400 mm. Please consult with SMC when exceeding 1400 mm strokes.

Note 5) Use a stroke of a length which is smaller than the effective cushion length may result in reduced air cushion performance. Refer to "Technical Data 1" on page 1901 for details on the effective cushion length.



Symbol

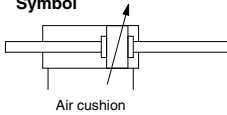

Air cushion



Made to Order
[Click here for details](#)

| Symbol | Specifications |
|--------|---|
| -XA | Change of rod end shape |
| -XB6 | Heat resistant cylinder (-10 to 150°C) |
| -XC3 | Special port location* |
| -XC4 | With heavy duty scraper |
| -XC5 | Heat resistant cylinder (-10 to 110°C) |
| -XC7 | Tie-rod, cushion valve, tie-rod nut, etc. made of stainless steel |
| -XC14 | Change of trunnion bracket mounting position |
| -XC15 | Change of tie-rod length |
| -XC22 | Fluororubber seal |
| -XC28 | Compact flange made of SS400 |
| -XC35 | With coil scraper |
| -XC58 | Water resistant/ Built-in hard plastic magnet* |
| -XC59 | Fluororubber seal/ Built-in hard plastic magnet* |
| -XC65 | Made of stainless steel (Combination of XC7 and XC68) |
| -XC68 | Made of stainless steel (with hard chrome plated piston rod) |
| -XC85 | Grease for food processing equipment |

For special port location (-XC3), the mounting bracket and port location can be determined using the standard product corresponding to the operating conditions.

* The cover shape is the same as the current product.

For made of stainless steel (-XC6), use made of stainless steel (with hard chrome plated piston rod) (-XC68) that the surface treatment is performed on the piston rod with the same specifications.

Refer to pages 517 to 523 for cylinders with auto switches.

- Auto switch proper mounting position (detection at stroke end) and its mounting height
- Operating range
- Minimum stroke for auto switch mounting
- Auto switch mounting brackets/Part no.

Minimum Stroke for Auto Switch Mounting

⚠ Caution

The minimum stroke for mounting varies with the auto switch type and cylinder mounting type. In particular, the center trunnion type needs careful attention. (For details, refer to pages 521 and 522.)

Rod Boot Material

| Symbol | Rod boot material | Max. ambient temperature |
|--------|--------------------------|--------------------------|
| J | Nylon tarpaulin | 70°C |
| K | Heat resistant tarpaulin | 110°C* |

* Maximum ambient temperature for the rod boot

Accessories

| Standard | Mounting | Basic | Foot | Flange | Center trunnion |
|----------|---------------------------------|-------------|------|--------|-----------------|
| | Option | Rod end nut | ● | ● | ● |
| | Single knuckle joint | ● | ● | ● | ● |
| | Double knuckle joint (with pin) | ● | ● | ● | ● |
| | With rod boot | ● | ● | ● | ● |

* Refer to page 485 for part numbers and dimensions.

Weights/Aluminum Tube (Steel Tube)

| Bore size (mm) | | (kg) | | | | | |
|---------------------------------------|---------------------------|---------------|------|------|------|------|------|
| | | 40 | 50 | 63 | 80 | 100 | |
| Basic weight | Basic | Aluminum tube | 0.92 | 1.38 | 1.86 | 3.32 | 4.55 |
| | | Steel tube | 0.97 | 1.44 | 1.96 | 3.5 | 4.83 |
| | Axial foot | Aluminum tube | 1.11 | 1.6 | 2.19 | 3.99 | 5.54 |
| | | Steel tube | 1.16 | 1.66 | 2.29 | 4.17 | 5.82 |
| | Flange | Aluminum tube | 1.29 | 1.83 | 2.65 | 4.77 | 6.47 |
| | | Steel tube | 1.34 | 1.89 | 2.75 | 4.95 | 6.75 |
| Trunnion | Aluminum tube | 1.28 | 1.86 | 2.66 | 4.87 | 6.83 | |
| | Steel tube | 1.33 | 1.92 | 2.76 | 5.05 | 7.11 | |
| Additional weight per 50 mm of stroke | All mounting brackets | Aluminum tube | 0.28 | 0.37 | 0.44 | 0.66 | 0.86 |
| | Steel tube | 0.35 | 0.47 | 0.55 | 0.89 | 1.15 | |
| Accessories | Single knuckle | 0.23 | 0.26 | 0.26 | 0.60 | 0.83 | |
| | Double knuckle (with pin) | 0.37 | 0.43 | 0.43 | 0.87 | 1.27 | |

Calculation:
(Example) CA2WL40-100
(Axial foot, ø40, 100 stroke)
● Basic weight
.....1.18 (Axial foot, ø40)
● Additional weight
.....0.28/50 stroke
● Cylinder stroke
.....100 stroke
1.18 + 0.28 x 100/50 = 1.74 kg

CA2W Series

Mounting Bracket Part No.

| Bore size (mm) | 40 | 50 | 63 | 80 | 100 |
|----------------|---------|---------|---------|---------|---------|
| Axial foot* | CA2-L04 | CA2-L05 | CA2-L06 | CA2-L08 | CA2-L10 |
| Flange | CA2-F04 | CA2-F05 | CA2-F06 | CA2-F08 | CA2-F10 |

* When axial foot brackets are used, order two pieces per cylinder.

Construction

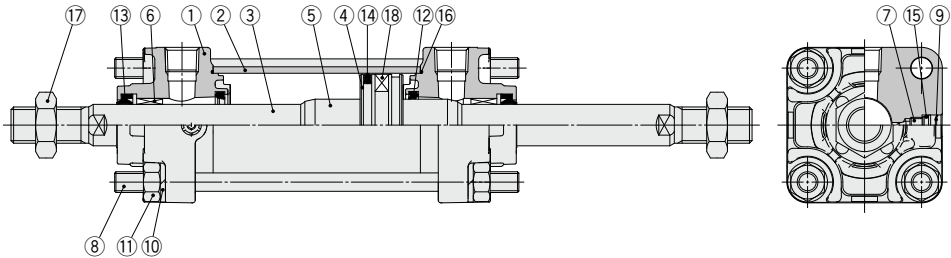

Component Parts

| No. | Description | Material | Q'ty | Note |
|-----|----------------------|---------------------|------|--------------------------|
| 1 | Rod cover | Aluminum die-casted | 2 | Trivalent chromated |
| 2 | Cylinder tube | Aluminum alloy | 1 | Hard anodized |
| 3 | Piston rod | Carbon steel | 1 | Hard chrome plating |
| 4 | Piston | Aluminum alloy | 1 | |
| 5 | Cushion ring | Aluminum alloy | 2 | Anodized |
| 6 | Bushing | Bearing alloy | 1 | |
| 7 | Cushion valve | Steel wire | 2 | Trivalent zinc chromated |
| 8 | Tie-rod | Carbon steel | 4 | Trivalent zinc chromated |
| 9 | Retaining ring | Spring steel | 2 | Phosphate coating |
| 10 | Spring washer | Steel wire | 8 | Trivalent zinc chromated |
| 11 | Tie-rod nut | Rolled steel | 8 | Trivalent zinc chromated |
| 12 | Cushion seal | Urethane | 2 | |
| 13 | Rod seal | NBR | 2 | |
| 14 | Piston seal | NBR | 1 | |
| 15 | Cushion valve seal | NBR | 2 | |
| 16 | Cylinder tube gasket | NBR | 2 | |
| 17 | Rod end nut | Rolled steel | 2 | Trivalent zinc chromated |
| 18 | Magnet | — | (1) | |

Replacement Parts: Seal Kit

| Bore size (mm) | Kit no. | Contents |
|----------------|----------------|-----------------------------------|
| | Pneumatic type | |
| 40 | CA2W40Z-PS | Set of the nos. 12, 13, 14, 16 |
| 50 | CA2W50Z-PS | |
| 63 | CA2W63Z-PS | |
| 80 | CA2W80Z-PS | |
| 100 | CA2W100Z-PS | |

* Do not disassemble the trunnion type. Refer to page 525.

* Seal kit includes 12, 13, 14, 16. Order the seal kit based on each bore size.

* Seal kit includes a grease pack (ø40, ø50: 10 g, ø63, ø80: 20 g, ø100: 30 g).
Order with the following part number when only the grease pack is needed.

Grease pack part number: GR-S-010 (10 g), GR-S-020 (20 g)

Air Cylinder: Standard Type **CA2W Series**

Basic: CA2WB

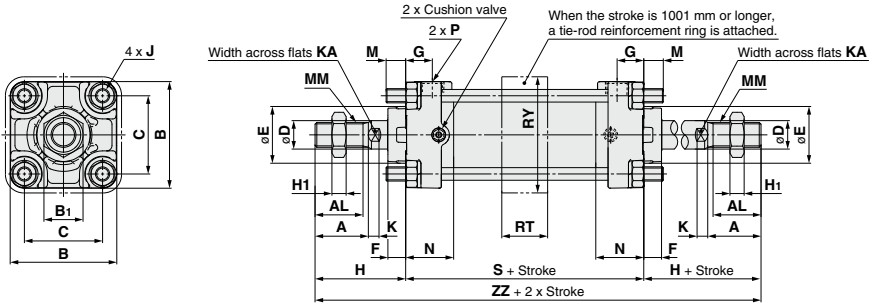

With rod boot (One side)

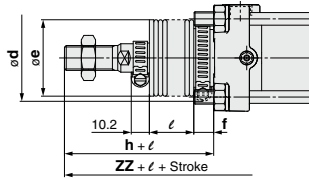

With rod boot (Both sides)

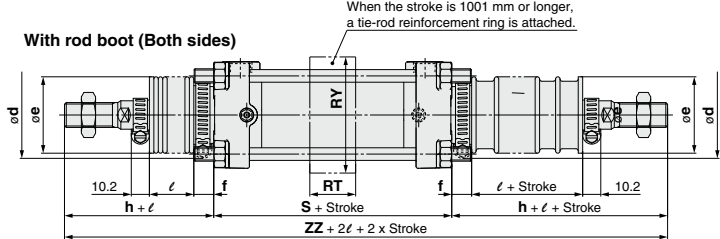

(mm)

| Bore size (mm) | A | AL | B | B ₁ | C | D | E | F | G | H ₁ | J | K | KA | M | MM |
|----------------|----|----|-----|----------------|----|----|----|----|----|----------------|------------|----|----|----|-----------|
| 40 | 30 | 27 | 60 | 22 | 44 | 16 | 32 | 10 | 15 | 8 | M8 x 1.25 | 6 | 14 | 11 | M14 x 1.5 |
| 50 | 35 | 32 | 70 | 27 | 52 | 20 | 40 | 10 | 17 | 11 | M8 x 1.25 | 7 | 18 | 11 | M18 x 1.5 |
| 63 | 35 | 32 | 85 | 27 | 64 | 20 | 40 | 10 | 17 | 11 | M10 x 1.25 | 7 | 18 | 14 | M18 x 1.5 |
| 80 | 40 | 37 | 102 | 32 | 78 | 25 | 52 | 14 | 21 | 13 | M12 x 1.75 | 10 | 22 | 17 | M22 x 1.5 |
| 100 | 40 | 37 | 116 | 41 | 92 | 30 | 52 | 14 | 21 | 16 | M12 x 1.75 | 10 | 26 | 17 | M26 x 1.5 |

| Bore size (mm) | N | P | RT | RY | S | Without rod boot | | With rod boot (One side) | | | | | | [Both sides] | |
|----------------|----|-----|----|-----|-----|------------------|-----|--------------------------|----|------|----|------------|-----|--------------|--|
| | | | | | | H | ZZ | d | e | f | h | ℓ | ZZ | ZZ | |
| 40 | 27 | 1/4 | 30 | 64 | 84 | 51 | 186 | 56 | 43 | 11.2 | 59 | 1/4 stroke | 194 | 202 | |
| 50 | 30 | 3/8 | 30 | 76 | 90 | 58 | 206 | 64 | 52 | 11.2 | 66 | 1/4 stroke | 214 | 222 | |
| 63 | 31 | 3/8 | 40 | 92 | 98 | 58 | 214 | 64 | 52 | 11.2 | 66 | 1/4 stroke | 222 | 230 | |
| 80 | 37 | 1/2 | 45 | 112 | 116 | 71 | 258 | 76 | 65 | 12.5 | 80 | 1/4 stroke | 267 | 276 | |
| 100 | 40 | 1/2 | 50 | 136 | 126 | 72 | 270 | 76 | 65 | 14.0 | 81 | 1/4 stroke | 279 | 288 | |

CJ1

CJP

CJ2

JCM

CM2

CM3

CG1

CG3

JMB

MB

MB1

CA2

CS1

CS2

D-□

-X□

Technical Data

CA2W Series

Axial Foot: CA2WL

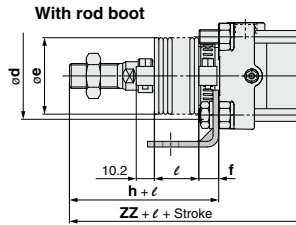
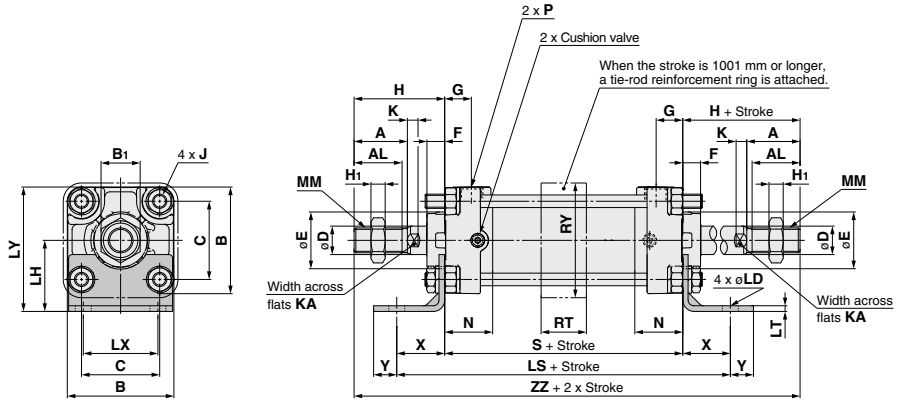

(mm)

| Bore size (mm) | A | AL | B | B ₁ | C | D | E | F | G | H _i | J | K | KA | LD | LH | LS | LT | LX | LY |
|----------------|----|----|-----|----------------|----|----|----|----|----|----------------|------------|----|----|------|----|-----|-----|----|-----|
| 40 | 30 | 27 | 60 | 22 | 44 | 16 | 32 | 10 | 15 | 8 | M8 x 1.25 | 6 | 14 | 9 | 40 | 138 | 3.2 | 42 | 70 |
| 50 | 35 | 32 | 70 | 27 | 52 | 20 | 40 | 10 | 17 | 11 | M8 x 1.25 | 7 | 18 | 9 | 45 | 144 | 3.2 | 50 | 80 |
| 63 | 35 | 32 | 85 | 27 | 64 | 20 | 40 | 10 | 17 | 11 | M10 x 1.25 | 7 | 18 | 11.5 | 50 | 166 | 3.2 | 59 | 93 |
| 80 | 40 | 37 | 102 | 32 | 78 | 25 | 52 | 14 | 21 | 13 | M12 x 1.75 | 10 | 22 | 13.5 | 65 | 204 | 4.5 | 76 | 116 |
| 100 | 40 | 37 | 116 | 41 | 92 | 30 | 52 | 14 | 21 | 16 | M12 x 1.75 | 10 | 26 | 13.5 | 75 | 212 | 6 | 92 | 133 |

| Bore size (mm) | MM | N | P | RT | RY | S | X | Y | Without rod boot | | With rod boot (One side) | | | | | | [Both sides] | |
|----------------|-----------|----|-----|----|-----|-----|----|----|------------------|-----|--------------------------|----|------|----|------------|-----|--------------|--|
| | | | | | | | | | H | ZZ | d | e | f | h | ℓ | ZZ | ZZ | |
| 40 | M14 x 1.5 | 27 | 1/4 | 30 | 64 | 84 | 27 | 13 | 51 | 186 | 56 | 43 | 11.2 | 59 | 1/4 stroke | 194 | 202 | |
| 50 | M18 x 1.5 | 30 | 3/8 | 30 | 76 | 90 | 27 | 13 | 58 | 206 | 64 | 52 | 11.2 | 66 | 1/4 stroke | 214 | 222 | |
| 63 | M18 x 1.5 | 31 | 3/8 | 40 | 92 | 98 | 34 | 16 | 58 | 214 | 64 | 52 | 11.2 | 66 | 1/4 stroke | 222 | 230 | |
| 80 | M22 x 1.5 | 37 | 1/2 | 45 | 112 | 116 | 44 | 16 | 71 | 258 | 76 | 65 | 12.5 | 80 | 1/4 stroke | 267 | 276 | |
| 100 | M26 x 1.5 | 40 | 1/2 | 50 | 136 | 126 | 43 | 17 | 72 | 270 | 76 | 65 | 14.0 | 81 | 1/4 stroke | 279 | 288 | |

Rod Flange: CA2WF

Stroke of 1000 mm or less

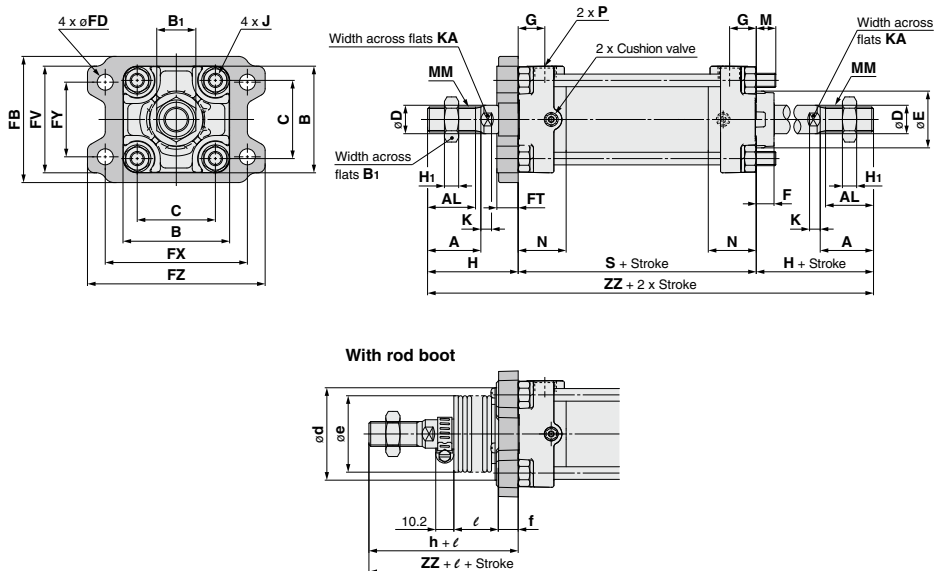

- CAJ1
- CJP
- CJ2
- JCM
- CM2
- CM3
- CG1
- CG3
- JMB
- MB
- MB1
- CA2**
- CS1
- CS2

| Bore size (mm) | A | AL | B | B ₁ | C | D | E | FB | FD | FT | FV | FX | FY | FZ | G | H ₁ | J | K | KA | M |
|----------------|----|----|-----|----------------|----|----|----|-----|------|----|-----|-----|----|-----|----|----------------|------------|----|----|----|
| 40 | 30 | 27 | 60 | 22 | 44 | 16 | 32 | 71 | 9 | 12 | 60 | 80 | 42 | 100 | 15 | 8 | M8 x 1.25 | 6 | 14 | 11 |
| 50 | 35 | 32 | 70 | 27 | 52 | 20 | 40 | 81 | 9 | 12 | 70 | 90 | 50 | 110 | 17 | 11 | M8 x 1.25 | 7 | 18 | 11 |
| 63 | 35 | 32 | 85 | 27 | 64 | 20 | 40 | 101 | 11.5 | 15 | 86 | 105 | 59 | 130 | 17 | 11 | M10 x 1.25 | 7 | 18 | 14 |
| 80 | 40 | 37 | 102 | 32 | 78 | 25 | 52 | 119 | 13.5 | 18 | 102 | 130 | 76 | 160 | 21 | 13 | M12 x 1.75 | 10 | 22 | 17 |
| 100 | 40 | 37 | 116 | 41 | 92 | 30 | 52 | 133 | 13.5 | 18 | 116 | 150 | 92 | 180 | 21 | 16 | M12 x 1.75 | 10 | 26 | 17 |

| Bore size (mm) | MM | N | P | S | Without rod boot | | With rod boot (One side) | | | | | Both sides | |
|----------------|-----------|----|-----|-----|------------------|-----|--------------------------|----|------|----|------------|------------|-----|
| | | | | | H | ZZ | *d | e | f | h | ℓ | ZZ | ZZ |
| 40 | M14 x 1.5 | 27 | 1/4 | 84 | 51 | 186 | 52 | 43 | 15 | 59 | 1/4 stroke | 194 | 202 |
| 50 | M18 x 1.5 | 30 | 3/8 | 90 | 58 | 206 | 58 | 52 | 15 | 66 | 1/4 stroke | 214 | 222 |
| 63 | M18 x 1.5 | 31 | 3/8 | 98 | 58 | 214 | 58 | 52 | 17.5 | 66 | 1/4 stroke | 222 | 230 |
| 80 | M22 x 1.5 | 37 | 1/2 | 116 | 71 | 258 | 80 | 65 | 21.5 | 80 | 1/4 stroke | 267 | 276 |
| 100 | M26 x 1.5 | 40 | 1/2 | 126 | 72 | 270 | 80 | 65 | 21.5 | 81 | 1/4 stroke | 279 | 288 |

★For installing an air cylinder, when a hole must be made to accommodate the rod portion, make sure to machine a hole that is larger than the outer diameter of the boot mounting bracket ød.

- D-□
- X□
- Technical Data

CA2W Series

Rod Flange: CA2WF

Stroke of 1001 mm or more

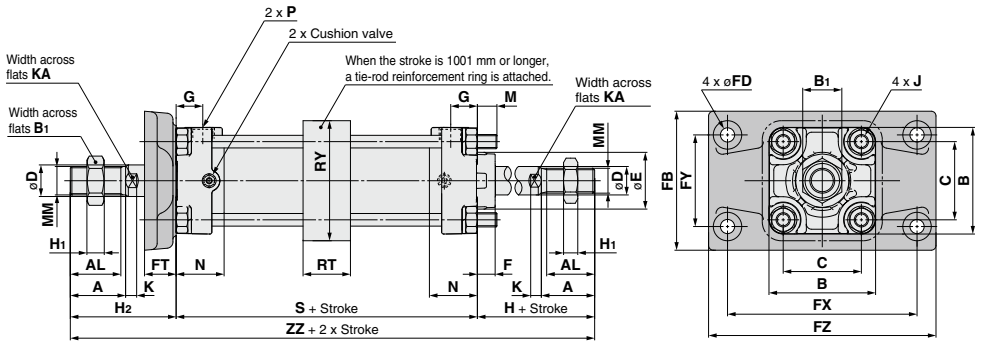

With rod boot

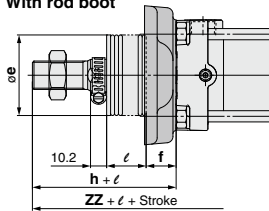

(mm)

| Bore size (mm) | A | AL | B | B ₁ | C | D | E | FB | FD | FT | FX | FY | FZ | G | H ₁ | J | K | KA | M |
|----------------|----|----|-----|----------------|----|----|----|-----|------|----|-----|-----|-----|----|----------------|------------|----|----|----|
| 40 | 30 | 27 | 60 | 22 | 44 | 16 | 32 | 71 | 9 | 12 | 80 | 42 | 100 | 15 | 8 | M8 x 1.25 | 6 | 14 | 11 |
| 50 | 35 | 32 | 70 | 27 | 52 | 20 | 40 | 88 | 9 | 20 | 120 | 58 | 144 | 17 | 11 | M8 x 1.25 | 7 | 18 | 6 |
| 63 | 35 | 32 | 85 | 27 | 64 | 20 | 40 | 105 | 11.5 | 23 | 140 | 64 | 170 | 17 | 11 | M10 x 1.25 | 7 | 18 | 10 |
| 80 | 40 | 37 | 102 | 32 | 78 | 25 | 52 | 124 | 13.5 | 28 | 164 | 84 | 198 | 21 | 13 | M12 x 1.75 | 10 | 22 | 12 |
| 100 | 40 | 37 | 116 | 41 | 92 | 30 | 52 | 140 | 13.5 | 29 | 180 | 100 | 220 | 21 | 16 | M12 x 1.75 | 10 | 26 | 12 |

| Bore size (mm) | MM | N | P | RT | RY | S | Without rod boot | | | With rod boot (One side) | | | | | | (Both sides) | |
|----------------|-----------|----|-----|----|-----|-----|------------------|----------------|-----|--------------------------|----|----|----|------------|-----|--------------|--|
| | | | | | | | H | H ₂ | ZZ | d | e | f | h | ℓ | ZZ | ZZ | |
| 40 | M14 x 1.5 | 27 | 1/4 | 30 | 76 | 84 | 51 | 51 | 186 | 52 | 43 | 15 | 59 | 1/4 stroke | 194 | 202 | |
| 50 | M18 x 1.5 | 30 | 3/8 | 30 | 76 | 90 | 58 | 67 | 215 | 58 | 52 | 19 | 66 | 1/4 stroke | 214 | 222 | |
| 63 | M18 x 1.5 | 31 | 3/8 | 40 | 92 | 98 | 58 | 71 | 227 | 58 | 52 | 19 | 66 | 1/4 stroke | 222 | 230 | |
| 80 | M22 x 1.5 | 37 | 1/2 | 45 | 112 | 116 | 71 | 87 | 274 | 80 | 65 | 21 | 80 | 1/4 stroke | 266 | 276 | |
| 100 | M26 x 1.5 | 40 | 1/2 | 50 | 136 | 126 | 72 | 89 | 287 | 80 | 65 | 21 | 81 | 1/4 stroke | 279 | 288 | |

Note 1) For flange type with bore size of $\phi 40$, the same bracket is used for all strokes.

Note 2) For models with bore size of $\phi 50$ to $\phi 100$ and stroke of 1001 mm or more, do not mount a flange bracket on basic cylinders since H dimension is different from those shown above. When rod flange type is used, order with the part number with bracket.

Air Cylinder: Standard Type **CA2W Series** Double Acting, Double Rod

Center Trunnion: CA2WT

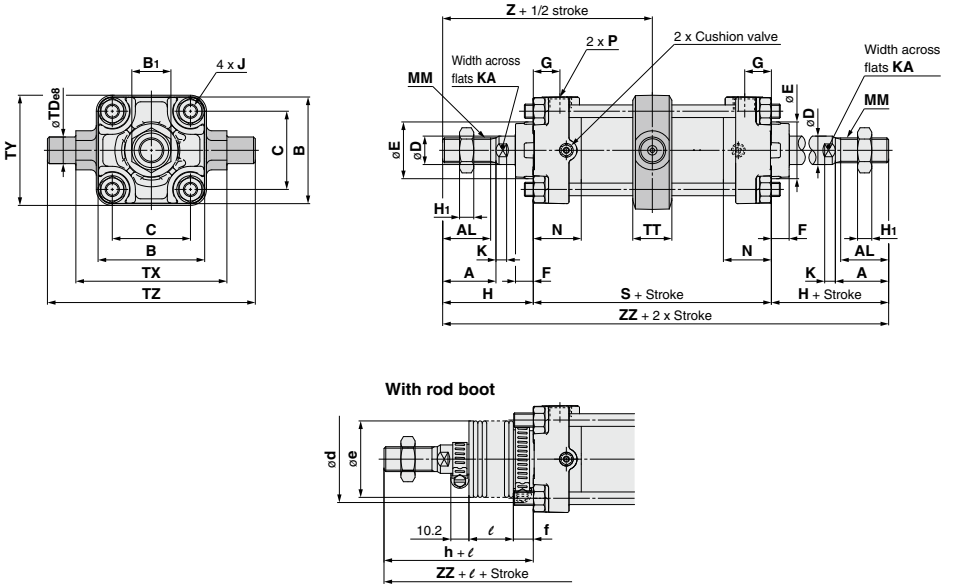

- CJ1
- CJP
- CJ2
- JCM
- CM2
- CM3
- CG1
- CG3
- JMB
- MB
- MB1
- CA2
- CS1
- CS2

| Bore size (mm) | | | | | | | | | | | | | | | | | | TD ₈₈ |
|-------------------|----|----|-----|----------------|----|----|----|----|----|----------------|------------|----|----|-----------|----|-----|-----|--|
| | A | AL | B | B ₁ | C | D | E | F | G | H ₁ | J | K | KA | MM | N | P | S | |
| 40 | 30 | 27 | 60 | 22 | 44 | 16 | 32 | 10 | 15 | 8 | M8 x 1.25 | 6 | 14 | M14 x 1.5 | 27 | 1/4 | 84 | 15 ^{+0.032} _{-0.059} |
| 50 | 35 | 32 | 70 | 27 | 52 | 20 | 40 | 10 | 17 | 11 | M8 x 1.25 | 7 | 18 | M18 x 1.5 | 30 | 3/8 | 90 | 15 ^{+0.032} _{-0.059} |
| 63 | 35 | 32 | 85 | 27 | 64 | 20 | 40 | 10 | 17 | 11 | M10 x 1.25 | 7 | 18 | M18 x 1.5 | 31 | 3/8 | 98 | 18 ^{+0.032} _{-0.059} |
| 80 | 40 | 37 | 102 | 32 | 76 | 25 | 52 | 14 | 21 | 13 | M12 x 1.75 | 10 | 22 | M22 x 1.5 | 37 | 1/2 | 116 | 25 ^{+0.040} _{-0.073} |
| 100 | 40 | 37 | 116 | 41 | 92 | 30 | 52 | 14 | 21 | 16 | M12 x 1.75 | 10 | 26 | M26 x 1.5 | 40 | 1/2 | 126 | 25 ^{+0.040} _{-0.073} |

| Bore size (mm) | TT | TX | TY | TZ | Without rod boot | | | With rod boot (One side) | | | | | | (Both sides) | | |
|-------------------|----|-----|-----|-----|------------------|-----|-----|--------------------------|----|------|----|------------|-----|--------------|-----|-----|
| | | | | | H | Z | ZZ | d | e | f | h | ℓ | Z | ZZ | Z | ZZ |
| 40 | 22 | 85 | 62 | 117 | 51 | 93 | 186 | 56 | 43 | 11.2 | 59 | 1/4 stroke | 101 | 194 | 101 | 202 |
| 50 | 22 | 95 | 74 | 127 | 58 | 103 | 206 | 64 | 52 | 11.2 | 66 | 1/4 stroke | 111 | 214 | 111 | 222 |
| 63 | 28 | 110 | 90 | 148 | 58 | 107 | 214 | 64 | 52 | 11.2 | 66 | 1/4 stroke | 115 | 222 | 115 | 230 |
| 80 | 34 | 140 | 110 | 192 | 71 | 129 | 258 | 76 | 65 | 12.5 | 80 | 1/4 stroke | 138 | 267 | 138 | 276 |
| 100 | 40 | 162 | 130 | 214 | 72 | 135 | 270 | 76 | 65 | 14.0 | 81 | 1/4 stroke | 144 | 279 | 144 | 288 |

* Do not disassemble the trunnion type. Refer to page 525.

- D-□
- X□
- Technical Data

Air Cylinder: Non-rotating Rod Type Double Acting, Single Rod

CA2K Series

ø40, ø50, ø63

How to Order

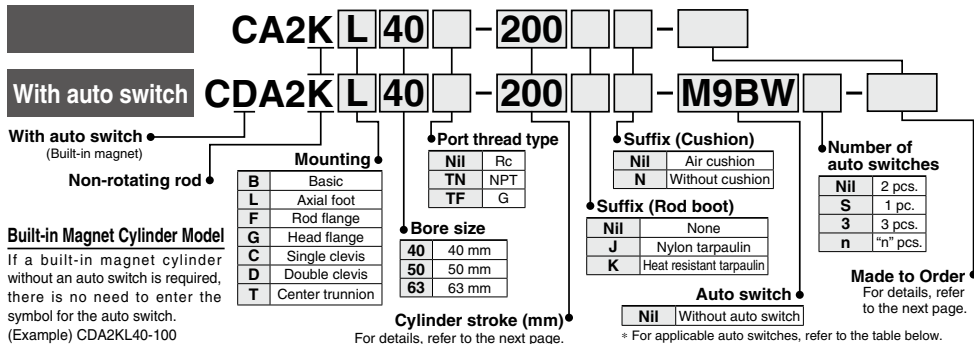

Applicable Auto Switches/Refer to pages 1575 to 1701 for further information on auto switches.

| Type | Special function | Electrical entry | Indicator light | Wiring (Output) | Load voltage | | Auto switch model | | Lead wire length (m) | | | | | Pre-wired connector | Applicable load | | | | | | |
|--|---|------------------|--------------------|---------------------|--------------|-----------|-------------------|---------------|----------------------|---------------|--------------|-------|------------|---------------------|-----------------|------------|---|------------|------------|---|------------|
| | | | | | DC | AC | Tie-rod mounting | Band mounting | 0.5 (Nil) | 1 (M) | 3 (L) | 5 (Z) | IC circuit | | Relay, PLC | | | | | | |
| Solid state auto switch | — | Grommet | No | 3-wire (NPN) | 24 V | 5 V, 12 V | — | M9N | ● | ● | ● | ○ | ○ | IC circuit | — | — | | | | | |
| | | | | 3-wire (PNP) | | | | — | G59 | ● | — | ● | ○ | | | | ○ | | | | |
| | | | | 2-wire | | | | — | M9P | ● | ● | ● | ○ | | | | ○ | | | | |
| | | | | — | | | | — | G5P | ● | — | ● | ○ | | | | ○ | | | | |
| | Diagnostic indication (2-color indicator) | Terminal conduit | Yes | 3-wire (NPN) | 24 V | 12 V | — | G39C | G39 | — | — | — | — | IC circuit | Relay, PLC | | | | | | |
| | | | | 2-wire | | | | K39C | K39 | — | — | — | — | | | | | | | | |
| | | | | 3-wire (NPN) | | | | M9NW | — | ● | ● | ● | ○ | | | ○ | | | | | |
| | | | | 3-wire (PNP) | | | | — | G59W | ● | — | ● | ○ | | | ○ | | | | | |
| | Water resistant (2-color indicator) | Grommet | No | 2-wire | 24 V | 12 V | — | M9PW | — | ● | ● | ● | ○ | ○ | — | — | | | | | |
| | | | | 3-wire (NPN) | | | | — | G5PW | ● | — | ● | ○ | ○ | | | | | | | |
| 3-wire (PNP) | | | | — | | | | M9BW | — | ● | ● | ● | ○ | ○ | | | | | | | |
| 2-wire | | | | — | | | | K59W | ● | — | ● | ○ | ○ | | | | | | | | |
| With diagnostic output (2-color indicator) | Grommet | No | 3-wire (NPN) | 24 V | 5 V, 12 V | — | M9NA*1 | — | ○ | ○ | ● | ○ | ○ | — | — | | | | | | |
| | | | 3-wire (PNP) | | | | — | M9PA*1 | — | ○ | ○ | ● | ○ | | | ○ | | | | | |
| | | | 2-wire | | | | — | M9BA*1 | — | ○ | ○ | ● | ○ | | | ○ | | | | | |
| | | | — | | | | — | G5BA*1 | — | — | — | — | — | | | — | | | | | |
| Magnetic field resistant (2-color indicator) | Terminal conduit | No | 4-wire (NPN) | 24 V | 5 V, 12 V | — | F59F | G59F | ● | — | ● | ○ | ○ | IC circuit | — | | | | | | |
| | | | 2-wire (Non-polar) | | | | — | P3DWA | — | ● | — | ● | ○ | | | ○ | | | | | |
| | | | — | | | | — | P4DW | — | — | — | — | — | | | — | ○ | | | | |
| | | | — | | | | — | — | — | — | — | — | — | | | — | ○ | | | | |
| Reed auto switch | — | Grommet | Yes | 3-wire (NPN equiv.) | 24 V | 12 V | 5 V | — | A96 | — | ● | — | ● | — | — | IC circuit | — | | | | |
| | | | | No | | | | | 2-wire | 100 V | A93 | — | ● | ● | ● | ● | — | IC circuit | Relay, PLC | | |
| | | | | | | | | | | 100 V or less | A90 | — | ● | — | ● | — | — | | | | |
| | | | | | | | | | | 100 V, 200 V | A54 | B54 | ● | — | ● | ● | — | | | | |
| | | | | | | | | | | 200 V or less | A64 | B64 | ● | — | ● | — | — | | | | |
| | | | | Yes | | | | | Terminal conduit | No | — | A33C | A33 | — | — | — | — | — | — | — | PLC |
| | | | | | | | | | | | — | A34C | A34 | — | — | — | — | — | — | — | Relay, PLC |
| | | | | | | | | | | | 100 V, 200 V | A44C | A44 | — | — | — | — | — | — | — | |
| — | A59W | B59W | ● | | — | ● | — | — | | | — | — | — | | | | | | | | |

*1 Water resistant type auto switches can be mounted on the above models, but in such case SMC cannot guarantee water resistance. Please contact SMC regarding water resistant types with the above model numbers.

* Lead wire length symbols: 0.5 m..... Nil (Example) M9NW * Solid state auto switches marked with "○" are produced upon receipt of order.

1 m..... M (Example) M9NW
3 m..... L (Example) M9NW
5 m..... Z (Example) M9NW

* Since there are other applicable auto switches than listed above, refer to page 523 for details.

* For details about auto switches with pre-wired connector, refer to pages 1649 and 1649.

* The D-A9□/M9□□/P3DWA□ auto switches are shipped together, (but not assembled). (However, auto switch mounting brackets are assembled for the D-A9□/M9□□ before shipment.)

Non-rotating accuracy: ±0.8°
Same mounting dimensions as those of standard cylinder



Symbol
Air cushion

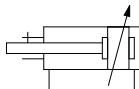

Made to Order
[Click here for details](#)

| Symbol | Specifications |
|--------|---|
| -XA□ | Change of rod end shape |
| -XC7 | Tie-rod, cushion valve, tie-rod nut, etc. made of stainless steel |
| -XC8 | Adjustable stroke cylinder/Adjustable extension type |
| -XC9 | Adjustable stroke cylinder/Adjustable retraction type |
| -XC10 | Dual stroke cylinder/Double rod type |
| -XC11 | Dual stroke cylinder/Single rod type |
| -XC14 | Change of trunnion bracket mounting position |
| -XC15 | Change of tie-rod length |
| -XC27 | Double clevis and double knuckle joint pins made of stainless steel |
| -XC28 | Compact flange made of SS400 |

Refer to pages 517 to 523 for cylinders with auto switches.

- Auto switch proper mounting position (detection at stroke end) and its mounting height
- Operating range
- Minimum stroke for auto switch mounting
- Auto switch mounting brackets/Part no.

Rod Boot Material

| Symbol | Rod boot material | Max. ambient temperature |
|----------|--------------------------|--------------------------|
| J | Nylon tarpaulin | 70°C |
| K | Heat resistant tarpaulin | 110°C* |

* Maximum ambient temperature for the rod boot itself.

Specifications

| Bore size (mm) | 40 | 50 | 63 |
|-------------------------------|---|----|----|
| Fluid | Air | | |
| Proof pressure | 1.5 MPa | | |
| Maximum operating pressure | 1.0 MPa | | |
| Minimum operating pressure | 0.05 MPa | | |
| Ambient and fluid temperature | Without auto switch: -10 to 70°C* With auto switch : -10 to 60°C* | | |
| Piston speed | 50 to 500 mm/s | | |
| Cushion | Air cushion | | |
| Stroke length tolerance | Up to 250 st: $^{+1.0}_0$, 251 to 600 st: $^{+1.4}_0$ | | |
| Rod non-rotating accuracy | ±0.8° | | |
| Allowable rotational torque | 0.44 N·m or less | | |
| Lubrication | Not required (Non-Lube) | | |
| Mounting | Basic, Axial foot, Rod flange, Head flange Single clevis, Double clevis, Center trunnion | | |

* No freezing

Standard Strokes

| Bore size | Standard stroke (mm) |
|---------------|---|
| 40 | 25, 50, 75, 100, 125, 150, 175, 200, 250, 300, 350, 400, 450, 500* |
| 50, 63 | 25, 50, 75, 100, 125, 150, 175, 200, 250, 300, 350, 400, 450, 500, 600* |

* Intermediate strokes not listed above are also available.

** Please consult with SMC for longer strokes than the strokes marked with "*".

*** Using a stroke of a length which is smaller than the effective cushion length may result in reduced air cushion performance. Refer to "Technical Data 1" on page 1901 for details on the effective cushion length.

Minimum Stroke for Auto Switch Mounting

⚠ Caution

1. The minimum stroke for mounting varies with the auto switch type and cylinder mounting type. In particular, the center trunnion type needs careful attention. (For details, refer to pages 521 and 522.)

Weights

| Bore size (mm) | 40 | 50 | 63 | |
|----------------|---------------------------------------|------|------|------|
| Basic weight | Basic | 0.88 | 1.32 | 1.91 |
| | Axial foot | 1.07 | 1.54 | 2.25 |
| | Flange | 1.25 | 1.77 | 2.70 |
| | Single clevis | 1.11 | 1.66 | 2.54 |
| | Double clevis | 1.15 | 1.75 | 2.70 |
| | Trunnion | 1.24 | 1.80 | 2.71 |
| | Additional weight per 50 mm of stroke | 0.20 | 0.25 | 0.30 |
| Accessories | Single knuckle | 0.23 | 0.26 | 0.26 |
| | Double knuckle (with pin) | 0.37 | 0.43 | 0.43 |

Calculation: (Example) **CA2KL40-100**

- Basic weight: 1.07 (Axial foot, ø40)
 - Additional weight: 0.20/50 stroke
 - Cylinder stroke : 100 stroke
- $1.07 + 0.20 \times 100/50 = 1.47 \text{ kg}$

Mounting Bracket Part No.

| Bore size (mm) | 40 | 50 | 63 |
|-----------------|---------|---------|---------|
| Axial foot* | CA2-L04 | CA2-L05 | CA2-L06 |
| Flange | CA2-F04 | CA2-F05 | CA2-F06 |
| Single clevis | CA2-C04 | CA2-C05 | CA2-C06 |
| Double clevis** | CA2-D04 | CA2-D05 | CA2-D06 |

* When axial foot brackets are used, order two pieces per cylinder.

** A clevis pin, flat washers and split pins are shipped together with double clevis.

CJ1

CJP

CJ2

JCM

CM2

CM3

CG1

CG3

JMB

MB

MB1

CA2

CS1

CS2

D-□

-X□

Technical Data

CA2K Series

⚠ Precautions

Be sure to read this before handling the products. Refer to back page 50 for Safety Instructions and pages 3 to 12 for Actuator and Auto Switch Precautions.

Handling

⚠ Caution

1. Avoid applications in which rotational torque is applied to the piston rod.

If rotational torque is applied, the non-rotating guide will be deformed, resulting in a loss of non-rotating accuracy. Also, to screw a bracket or a nut onto the threaded portion at the end of the piston rod, make sure that the piston rod is fully retracted, and place a wrench on the parallel section of the rod that protrudes. To tighten, take precautions to prevent the tightening torque from being applied to the non-rotating guide.

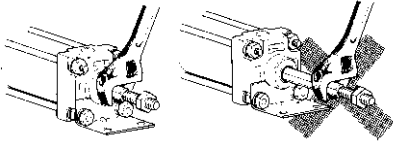

Disassembly/Replacement

⚠ Caution

1. Please consult with SMC when the rod seal is to be replaced.
A rod seal may allow air leakage depending on the position where it is installed. Therefore, please consult with SMC when a rod seal is to be replaced.
2. Do not replace the non-rotating guide.
Since the non-rotating guide is press fitted, the entire cover assembly needs to be replaced instead of a single part.

Construction

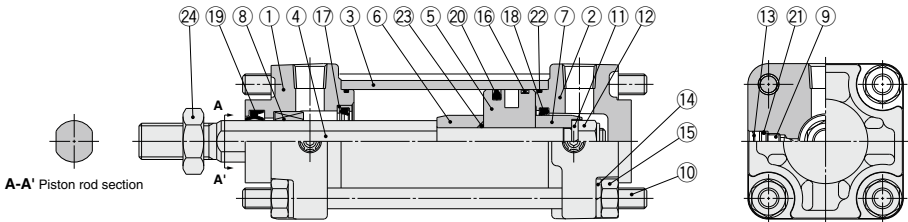

Component Parts

| No. | Description | Material | Note |
|-----|--------------------|--------------------------------|--------------------------|
| 1 | Rod cover | Aluminum alloy | Metallic painted |
| 2 | Head cover | Aluminum die-casted | Metallic painted |
| 3 | Cylinder tube | Aluminum alloy | Hard anodized |
| 4 | Piston rod | Carbon steel | Hard chrome plating |
| 5 | Piston | Aluminum alloy | Chromated |
| 6 | Cushion ring A | Rolled steel | Zinc chromated |
| 7 | Cushion ring B | Rolled steel | Zinc chromated |
| 8 | Non-rotating guide | Oil-impregnated sintered alloy | |
| 9 | Cushion valve | Steel wire | Trivalent zinc chromated |
| 10 | Tie-rod | Carbon steel | Trivalent zinc chromated |
| 11 | Spring washer | Steel wire | Trivalent zinc chromated |
| 12 | Piston nut | Rolled steel | Trivalent zinc chromated |
| 13 | Retaining ring | Spring steel | Phosphate coating |
| 14 | Spring washer | Steel wire | Trivalent zinc chromated |
| 15 | Tie-rod nut | Rolled steel | Trivalent zinc chromated |
| 16 | Wear ring | Resin | |

| No. | Description | Material | Note |
|-----|----------------------|----------------|--------------------------|
| 17 | Cushion seal holder | Aluminum alloy | |
| 18 | Cushion seal | Urethane | |
| 19 | Rod seal | NBR | |
| 20 | Piston seal | NBR | |
| 21 | Cushion valve seal | NBR | |
| 22 | Cylinder tube gasket | NBR | |
| 23 | Piston gasket | NBR | O-ring |
| 24 | Rod end nut | Rolled steel | Trivalent zinc chromated |

Replacement Parts: Seal Kit

| Bore size (mm) | Kit no. | Contents |
|----------------|-----------|---------------------------------|
| 40 | CA2K40-PS | Set of the nos. 18, 19, 20, 22. |
| 50 | CA2K50-PS | |
| 63 | CA2K63-PS | |

- * Seal kit includes 18, 19, 20 and 22. Order the seal kit based on each bore size.
 - * Do not disassemble the trunion type. Refer to page 525.
 - * Seal kit includes a grease pack (ø40, ø50: 10 g, over ø63: 20 g).
- Order with the following part number when only the grease pack is needed.
Grease pack part number: GR-S-010 (10 g), GR-S-020 (20 g)

Air Cylinder: Non-rotating Rod Type Double Acting, Single Rod **CA2K Series**

Basic: CA2KB

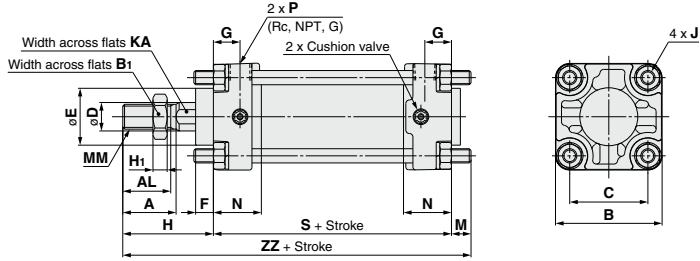

With rod boot

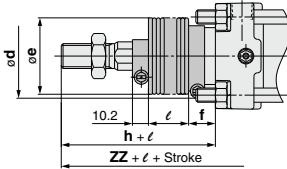

| Bore size (mm) | Stroke range (mm) | | (mm) | | | | | | | | | | | | | |
|----------------|-------------------|---------------|------|----|----|----------------|----|----|----|----|----|----------------|------------|----|----|-----------|
| | Without rod boot | With rod boot | A | AL | B | B ₁ | C | D | E | F | G | H ₁ | J | KA | M | MM |
| 40 | Up to 500 | 20 to 500 | 30 | 27 | 60 | 22 | 44 | 16 | 32 | 10 | 15 | 8 | M8 x 1.25 | 14 | 11 | M14 x 1.5 |
| 50 | Up to 600 | 20 to 600 | 35 | 32 | 70 | 27 | 52 | 20 | 40 | 10 | 17 | 11 | M8 x 1.25 | 18 | 11 | M18 x 1.5 |
| 63 | Up to 600 | 20 to 600 | 35 | 32 | 85 | 27 | 64 | 20 | 40 | 10 | 17 | 11 | M10 x 1.25 | 18 | 14 | M18 x 1.5 |

| Bore size (mm) | N | P | S | Without rod boot | | With rod boot | | | | | |
|----------------|----|-----|----|------------------|-----|---------------|----|------|----|------------|-----|
| | | | | H | ZZ | d | e | f | h | ℓ | ZZ |
| 40 | 27 | 1/4 | 84 | 51 | 146 | 56 | 43 | 11.2 | 59 | 1/4 stroke | 154 |
| 50 | 30 | 3/8 | 90 | 58 | 159 | 64 | 52 | 11.2 | 66 | 1/4 stroke | 167 |
| 63 | 31 | 3/8 | 98 | 58 | 170 | 64 | 52 | 11.2 | 66 | 1/4 stroke | 178 |

The dimensions for each mounting type and the dimensions of accessories (options) are the same as the standard double acting single rod model. Refer to pages 476 to 485.

- CJ1
- CJP
- CJ2
- JCM
- CM2
- CM3
- CG1
- CG3
- JMB
- MB
- MB1
- CA2**
- CS1
- CS2

- D-□
- X□
- Technical Data

Air Cylinder: Non-rotating Rod Type Double Acting, Double Rod

CA2KW Series

ø40, ø50, ø63

How to Order

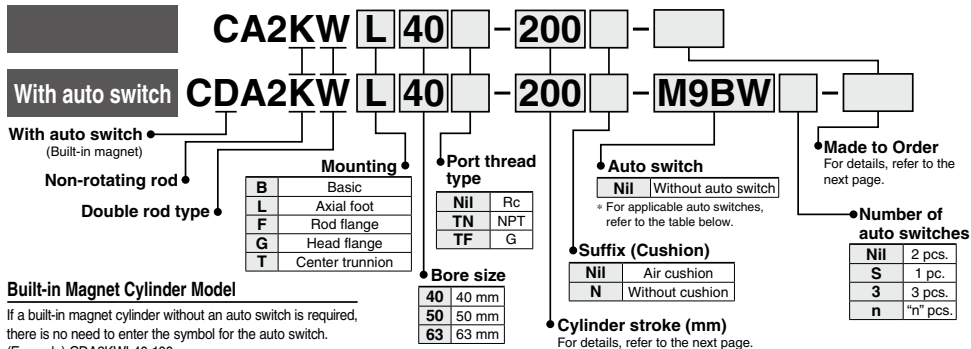

Applicable Auto Switches/Refer to pages 1575 to 1701 for further information on auto switches.

| Type | Special function | Electrical entry | Indicator light | Wiring (Output) | Load voltage | | Auto switch model | | Lead wire length (m) | | | | | Pre-wired connector | Applicable load | | |
|--|--|------------------|--------------------|---------------------|--------------|--------------|-------------------|---------------|----------------------|-------|-------|-------|---|---------------------|-----------------|------------|------------|
| | | | | | DC | AC | Tie-rod mounting | Band mounting | 0.5 (Nil) | 1 (M) | 3 (L) | 5 (Z) | | | | | |
| Solid state auto switch | — | Grommet | No | 3-wire (NPN) | 24 V | 5 V, 12 V | — | M9N | ● | ● | ● | ○ | ○ | — | IC circuit | | |
| | | | | 3-wire (PNP) | | | | G59 | ● | ● | ● | ○ | ○ | | | | |
| | | 2-wire | | 12 V | M9B | ● | ● | ● | ○ | ○ | — | — | | | | | |
| | | 3-wire (NPN) | | | K59 | ● | ● | ● | ○ | ○ | | | | | | | |
| | Diagnostic indication (2-color indicator) | Terminal conduit | Yes | 2-wire | 24 V | 12 V | — | G39C | — | — | — | — | — | — | — | | |
| | | | | 3-wire (NPN) | | | | G39 | — | — | — | — | — | | | | |
| | Water resistant (2-color indicator) | Grommet | No | 3-wire (NPN) | 24 V | 5 V, 12 V | — | M9NW | ● | ● | ● | ○ | ○ | — | IC circuit | | |
| | | | | 3-wire (PNP) | | | | G59W | ● | ● | ● | ○ | ○ | | | | |
| | With diagnostic output (2-color indicator) | Terminal conduit | Yes | 2-wire | 24 V | 12 V | — | M9PW | ● | ● | ● | ○ | ○ | — | IC circuit | | |
| | | | | 3-wire (NPN) | | | | G5PW | ● | ● | ● | ○ | ○ | | | | |
| Magnetic field resistant (2-color indicator) | Grommet | No | 2-wire | 24 V | 12 V | — | M9BW | ● | ● | ● | ○ | ○ | — | — | | | |
| | | | 3-wire (NPN) | | | | K59W | ● | ● | ● | ○ | ○ | | | | | |
| — | Terminal conduit | Yes | 3-wire (NPN) | 24 V | 5 V, 12 V | — | M9NA*1 | — | ○ | ○ | ● | ○ | — | — | | | |
| | | | 3-wire (PNP) | | | | M9PA*1 | — | ○ | ○ | ● | ○ | | | | | |
| — | DIN terminal | Yes | 2-wire (Non-polar) | 24 V | 12 V | — | M9BA*1 | — | ○ | ○ | ● | ○ | — | — | | | |
| | | | 4-wire (NPN) | | | | G5BA*1 | — | ○ | ○ | ● | ○ | | | | | |
| Reed auto switch | Diagnostic indication (2-color indicator) | Grommet | Yes | 3-wire (NPN equiv.) | 24 V | 12 V | — | A96 | — | ● | — | ● | — | — | IC circuit | | |
| | | | | No | | | | A93 | — | ● | ● | ● | ● | | | — | IC circuit |
| | | | | Yes | | | | A90 | — | ● | — | ● | — | | | | |
| | | Terminal conduit | Yes | 2-wire | 24 V | 12 V | — | 100 V or less | A54 | B54 | ● | — | ● | ● | — | Relay, PLC | |
| | | | | 100 V, 200 V | | | | A64 | B64 | ● | — | ● | — | | | | |
| | | | | 200 V or less | | | | A33C | A33 | — | — | — | — | | | | |
| DIN terminal | Yes | 2-wire | 24 V | 12 V | — | 100 V, 200 V | A34C | A34 | — | — | — | — | — | Relay, PLC | | | |
| | | — | | | | A44C | A44 | — | — | — | — | | | | | | |
| | | — | | | | A59W | B59W | — | — | ● | — | | | | | | |

*1 Water resistant type auto switches can be mounted on the above models, but in such case SMC cannot guarantee water resistance. Please contact SMC regarding water resistant types with the above model numbers.

* Lead wire length symbols: 0.5 m..... Nil (Example) M9NW * Solid state auto switches marked with "○" are produced upon receipt of order.

1 m..... M (Example) M9NWM
 3 m..... L (Example) M9NWL
 5 m..... Z (Example) M9NWX

* Since there are other applicable auto switches than listed above, refer to page 523 for details.

* For details about auto switches with pre-wired connector, refer to pages 1648 and 1649.

* The D-A9□/M9□□□□P3DWA□ auto switches are shipped together, (but not assembled). (However, auto switch mounting brackets are assembled for the D-A9□/M9□□□ before shipment.)

Non-rotating accuracy: $\pm 0.8^\circ$

Same mounting dimensions as those of standard cylinder

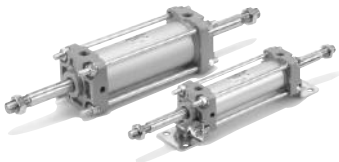

Symbol

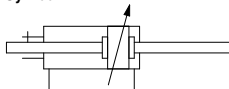

Made to Order
[Click here for details](#)

| Symbol | Specifications |
|--------|---|
| -XC7 | Tie-rod, cushion valve, tie-rod nut, etc. made of stainless steel |
| -XC14 | Change of trunnion bracket mounting position |
| -XC15 | Change of tie-rod length |
| -XC28 | Compact flange made of SS400 |

Refer to pages 517 to 523 for cylinders with auto switches.

- Auto switch proper mounting position (detection at stroke end) and its mounting height
- Operating range
- Minimum stroke for auto switch mounting
- Auto switch mounting brackets/Part no.

Production of Types with Rod Boot

CA2KW series is also available with rod boot. Please consult with SMC for more information.

Specifications

| Bore size (mm) | 40 | 50 | 63 |
|-------------------------------|--|----|----|
| Fluid | Air | | |
| Proof pressure | 1.5 MPa | | |
| Maximum operating pressure | 1.0 MPa | | |
| Minimum operating pressure | 0.08 MPa | | |
| Ambient and fluid temperature | Without auto switch: -10 to 70°C^* With auto switch : -10 to 60°C^* | | |
| Piston speed | 50 to 500 mm/s | | |
| Cushion | Air cushion | | |
| Stroke length tolerance | Up to 250 st: $^{+1.8}_0$, 251 to 600 st: $^{+1.4}_0$ | | |
| Rod non-rotating accuracy | $\pm 0.8^\circ$ | | |
| Allowable rotational torque | 0.44 N-m or less | | |
| Lubrication | Not required (Non-lube) | | |
| Mounting | Basic, Axial foot, Rod flange, Head flange, Center trunnion | | |

* No freezing

Standard Strokes

| Bore size | Standard stroke (mm) |
|-----------|---|
| 40 | 25, 50, 75, 100, 125, 150, 175, 200, 250, 300, 350, 400, 450, 500* |
| 50, 63 | 25, 50, 75, 100, 125, 150, 175, 200, 250, 300, 350, 400, 450, 500, 600* |

* Intermediate strokes not listed above are also available.

** Please consult with SMC for longer strokes than the strokes marked with "*".

*** Using a stroke of a length which is smaller than the effective cushion length may result in reduced air cushion performance. Refer to "Technical Data 1" on page 1901 for details on the effective cushion length.

Minimum Stroke for Auto Switch Mounting

⚠ Caution

1. The minimum stroke for mounting varies with the auto switch type and cylinder mounting type. In particular, the center trunnion type needs careful attention. (For details, refer to pages 521 and 522.)

Weights/Aluminum Tube

| Bore size (mm) | 40 | 50 | 63 | |
|---------------------------------------|---------------------------|------|------|------|
| Basic weight | Basic | 1.01 | 1.54 | 2.17 |
| | Axial foot | 1.20 | 1.76 | 2.50 |
| | Flange | 1.38 | 1.99 | 2.96 |
| | Trunnion | 1.37 | 2.02 | 2.97 |
| Additional weight per 50 mm of stroke | | 0.27 | 0.36 | 0.42 |
| Accessories | Single knuckle | 0.23 | 0.26 | 0.26 |
| | Double knuckle (with pin) | 0.37 | 0.43 | 0.43 |

Calculation: (Example) **CA2KWL40-100**

- Basic weight.....1.20 (Axial foot, $\phi 40$)
- Additional weight....0.27/50 stroke
- Cylinder stroke100 stroke

$$1.20 + 0.27 \times 100/50 = 1.74 \text{ kg}$$

Mounting Bracket Part No.

| Bore size (mm) | 40 | 50 | 63 |
|----------------|---------|---------|---------|
| Axial foot* | CA2-L04 | CA2-L05 | CA2-L06 |
| Flange | CA2-F04 | CA2-F05 | CA2-F06 |

* When axial foot brackets are used, order two pieces per cylinder.

CJ1

CJP

CJ2

JCM

CM2

CM3

CG1

CG3

JMB

MB

MB1

CA2

CS1

CS2

D-□

-X□

Technical Data

CA2KW Series

Construction

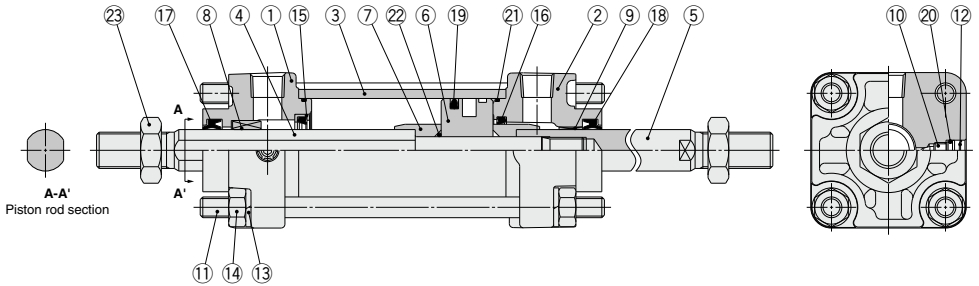

Component Parts

| No. | Description | Material | Note |
|-----|----------------------|--------------------------------|--------------------------|
| 1 | Rod cover A | Aluminum alloy | Metallic painted |
| 2 | Rod cover B | Aluminum die-casted | Metallic painted |
| 3 | Cylinder tube | Aluminum alloy | Hard anodized |
| 4 | Piston rod A | Carbon steel | Hard chrome plating |
| 5 | Piston rod B | Carbon steel | Hard chrome plating |
| 6 | Piston | Aluminum alloy | Chromated |
| 7 | Cushion ring | Rolled steel | Zinc chromated |
| 8 | Non-rotating guide | Oil-impregnated sintered alloy | |
| 9 | Bushing | Bearing alloy | |
| 10 | Cushion valve | Steel wire | Trivalent zinc chromated |
| 11 | Tie-rod | Carbon steel | Trivalent zinc chromated |
| 12 | Retaining ring | Spring steel | Phosphate coating |
| 13 | Spring washer | Steel wire | Trivalent zinc chromated |
| 14 | Tie-rod nut | Rolled steel | Trivalent zinc chromated |
| 15 | Cushion seal holder | Aluminum alloy | |
| 16 | Cushion seal | Urethane | |
| 17 | Rod seal A | NBR | |
| 18 | Rod seal B | NBR | |
| 19 | Piston seal | NBR | |
| 20 | Cushion valve seal | NBR | |
| 21 | Cylinder tube gasket | NBR | |
| 22 | Piston gasket | NBR | O-ring |
| 23 | Rod end nut | Rolled steel | Trivalent zinc chromated |

Replacement Parts: Seal Kit

| Bore size (mm) | Kit no. | Contents |
|----------------|------------|-------------------------------------|
| 40 | CA2KW40-PS | Set of the nos. 16, 17, 18, 19, 21. |
| 50 | CA2KW50-PS | |
| 63 | CA2KW63-PS | |

* Seal kit includes 16, 17, 18, 19, and 21. Order the seal kit based on each bore size.

* Do not disassemble the trunnion type. Refer to page 525.

* Seal kit includes a grease pack (ø40, ø50: 10 g, ø63, ø80: 20 g, ø100: 30 g).

Order with the following part number when only the grease pack is needed.
Grease pack part number: GR-S-010 (10 g), GR-S-020 (20 g)

Air Cylinder: Non-rotating Rod Type Double Acting, Double Rod **CA2KW Series**

Basic: CA2KWB

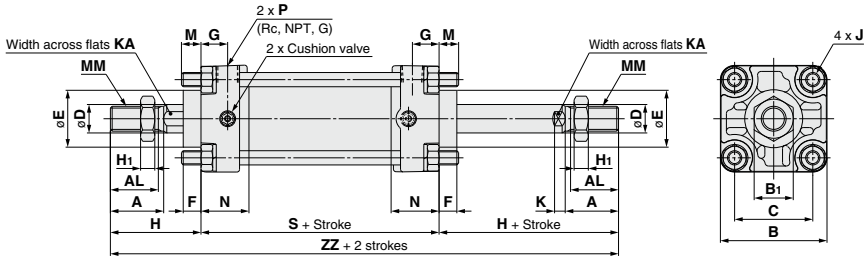

| Bore size (mm) | Stroke range (mm) | A | AL | B | B ₁ | C | D | E | F | G | H ₁ | J | K | KA | M | MM | N | P | S | H | ZZ |
|----------------|-------------------|----|----|----|----------------|----|----|----|----|----|----------------|------------|---|----|----|-----------|----|-----|----|----|-----|
| 40 | Up to 500 | 30 | 27 | 60 | 22 | 44 | 16 | 32 | 10 | 15 | 8 | M8 x 1.25 | 6 | 14 | 11 | M14 x 1.5 | 27 | 1/4 | 84 | 51 | 186 |
| 50 | Up to 600 | 35 | 32 | 70 | 27 | 52 | 20 | 40 | 10 | 17 | 11 | M8 x 1.25 | 7 | 18 | 11 | M18 x 1.5 | 30 | 3/8 | 90 | 58 | 206 |
| 63 | Up to 600 | 35 | 32 | 85 | 27 | 64 | 20 | 40 | 10 | 17 | 11 | M10 x 1.25 | 7 | 18 | 14 | M18 x 1.5 | 31 | 3/8 | 98 | 58 | 214 |

The dimensions for each mounting type are the same as the standard double acting double rod model. Refer to pages 490 to 493. For details about accessories (options), refer to page 485.

CJ1

CJP

CJ2

JCM

CM2

CM3

CG1

CG3

JMB

MB

MB1

CA2

CS1

CS2

D-□

-X□

Technical Data

Air Cylinder: With End Lock

CBA2 Series

ø40, ø50, ø63, ø80, ø100

How to Order

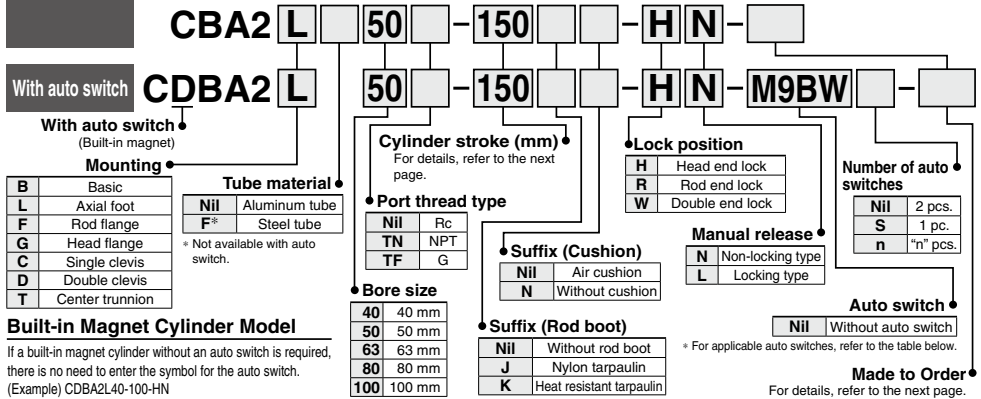

Applicable Auto Switches/Refer to pages 1575 to 1701 for further information on auto switches.

| Type | Special function | Electrical entry | Indicator light | Wiring (Output) | Load voltage | | Auto switch model | | Lead wire length (m) | | | | Pre-wired connector | Applicable load | | | |
|--|---|----------------------------------|------------------|---------------------|--------------|-----------|-------------------|--------------------|----------------------|-------|-------|-------|---------------------|-----------------|------------|------------|-----|
| | | | | | DC | AC | Tie-rod mounting | Band mounting | 0.5 (Nil) | 1 (M) | 3 (L) | 5 (Z) | | | | | |
| Solid state auto switch | — | Grommet | — | 3-wire (NPN) | 24 V | 5 V, 12 V | — | M9N | ● | ● | ● | ○ | ○ | IC circuit | — | | |
| | | | | 3-wire (PNP) | | | | G59 | ● | ● | ● | ○ | ○ | | | | |
| | | | | 2-wire | | | | M9P | ● | ● | ● | ○ | ○ | | | | |
| | | | | 3-wire (NPN) | | | | G5P | ● | ● | ● | ○ | ○ | | | | |
| | | | | 2-wire | | | | M9B | ● | ● | ● | ○ | ○ | | | | |
| | | | | 3-wire (PNP) | | | | K59 | ● | ● | ● | ○ | ○ | | | | |
| | Diagnostic indication (2-color indicator) | Yes | Terminal conduit | — | 3-wire (NPN) | 12 V | 5 V, 12 V | — | G39C | ● | ● | ● | ○ | ○ | IC circuit | Relay, PLC | |
| | | | | | 2-wire | | | | G39 | ● | ● | ● | ○ | ○ | | | |
| | | | | | 3-wire (NPN) | | | | K39 | ● | ● | ● | ○ | ○ | | | |
| | | | | | 3-wire (PNP) | | | | M9NW | ● | ● | ● | ○ | ○ | | | |
| | | | | | 2-wire | | | | M9PW | ● | ● | ● | ○ | ○ | | | |
| | | | | | 3-wire (PNP) | | | | G5PW | ● | ● | ● | ○ | ○ | | | |
| Water resistant (2-color indicator) | Grommet | — | — | 2-wire | 24 V | 12 V | — | M9BW | ● | ● | ● | ○ | ○ | — | — | | |
| | | | | 3-wire (NPN) | | | | K59W | ● | ● | ● | ○ | ○ | | | | |
| | | | | 3-wire (PNP) | | | | M9NA ^{*1} | — | ○ | ○ | ○ | ○ | | | | |
| | | | | 2-wire | | | | M9PA ^{*1} | — | ○ | ○ | ○ | ○ | | | | |
| | | | | 2-wire | | | | M9BA ^{*1} | — | ○ | ○ | ○ | ○ | | | | |
| | | | | 4-wire (NPN) | | | | G5BA ^{*1} | — | ○ | ○ | ○ | ○ | | | | |
| With diagnostic output (2-color indicator) Magnetic field resistant (2-color indicator) | Grommet | — | — | 2-wire (Non-polar) | 24 V | 5 V, 12 V | — | F59F | ● | ● | ● | ○ | ○ | IC circuit | — | | |
| | | | | 2-wire | | | | G59F | ● | ● | ● | ○ | ○ | | | | |
| | | | | 3-wire (NPN equiv.) | | | | P3DWA | ● | ● | ● | ○ | ○ | | | | |
| | | | | 3-wire (NPN equiv.) | | | | P4DW | ● | ● | ● | ○ | ○ | | | | |
| | | | | 2-wire | | | | A96 | ● | ● | ● | ○ | ○ | | | | |
| | | | | 2-wire | | | | A93 | ● | ● | ● | ○ | ○ | | | | |
| Reed auto switch | — | Grommet | Yes | 3-wire (NPN equiv.) | 24 V | 12 V | — | A93 | ● | ● | ● | ○ | ○ | IC circuit | Relay, PLC | | |
| | | | | | | | | No | A90 | ● | ● | ● | ○ | | | ○ | |
| | | | | | | | | Yes | A54 | B54 | ● | ● | ● | | | ○ | ○ |
| | | | | | | | | No | A64 | B64 | ● | ● | ● | | | ○ | ○ |
| | | Terminal conduit DIN terminal | Yes | — | — | 2-wire | 24 V | 12 V | — | A33C | A33 | — | — | — | — | — | PLC |
| | | | | | | | | | | A34C | A34 | — | — | — | — | | |
| | | | | | | | | | | A44C | A44 | — | — | — | — | | |
| | | | | | | | | | | A59W | B59W | ● | ● | ● | ○ | | |
| Diagnostic indication (2-color indicator) | Grommet | — | — | — | — | — | — | A96 | B59W | ● | ● | ● | ○ | ○ | — | Relay, PLC | |
| | | | | | | | | A93 | — | — | — | — | — | | | | |
| | | | | | | | | A54 | B54 | ● | ● | ● | ○ | ○ | | | |
| | | | | | | | | A64 | B64 | ● | ● | ● | ○ | ○ | | | |

*1 Water resistant type auto switches can be mounted on the above models, but in such case SMC cannot guarantee water resistance. Please contact SMC regarding water resistant types with the above model numbers.

* Lead wire length symbols: 0.5 m..... Nil (Example) M9NW
1 m..... M (Example) M9NWM
3 m..... L (Example) M9NWL
5 m..... Z (Example) M9NWX

* Solid state auto switches marked with "○" are produced upon receipt of order.

* Since there are other applicable auto switches than listed above, refer to page 523 for details.

* For details about auto switches with pre-wired connector, refer to pages 1648 and 1649.

* The D-A9□/M9□□/P3DWA□ auto switches are shipped together, (but not assembled). (However, auto switch mounting brackets are assembled for the D-A9□/M9□□ before shipment.)

Maintains the cylinder's original position even if the air supply is interrupted.

When air is discharged at the stroke end position, the lock engages to maintain the rod in that position.

Same dimensions as those of the standard cylinder (CA2 series)
Non-locking and locking types are standard for manual release.

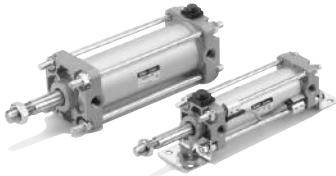

Symbol
Air cushion

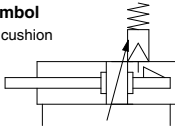

Made to Order
[Click here for details](#)

| Symbol | Specifications |
|----------|---|
| -XA□ | Change of rod end shape |
| -XB6 | Heat resistant cylinder (-10 to 150°C) |
| -XC3 | Special port location |
| -XC4 *1 | With heavy duty scraper |
| -XC6 *1 | Made of stainless steel |
| -XC7 | Tie-rod, cushion valve, tie-rod nut, etc. made of stainless steel |
| -XC8 *1 | Adjustable stroke cylinder/Adjustable extension type |
| -XC9 *2 | Adjustable stroke cylinder/Adjustable retraction type |
| -XC10 | Dual stroke cylinder/Double rod type |
| -XC14 | Change of trunnion bracket mounting position |
| -XC15 | Change of tie-rod length |
| -XC22 | Fluororubber seal |
| -XC27 | Double clevis and double knuckle joint pins made of stainless steel |
| -XC28 | Compact flange made of SS400 |
| -XC29 | Double knuckle joint with spring pin |
| -XC35 *1 | With coil scraper |

*1 For head end lock only
 *2 For rod end lock only

Refer to pages 517 to 523 for cylinders with auto switches.

- Auto switch proper mounting position (detection at stroke end) and its mounting height
- Operating range
- Minimum stroke for auto switch mounting
- Auto switch mounting brackets/Part no.

Specifications

| Bore size (mm) | 40 | 50 | 63 | 80 | 100 |
|--------------------------------------|---|----|----|----|-----|
| Fluid | Air | | | | |
| Proof pressure | 1.5 MPa | | | | |
| Maximum operating pressure | 1.0 MPa | | | | |
| Minimum operating pressure | 0.15 MPa*1 | | | | |
| Ambient and fluid temperature | Without auto switch: -10 to 70°C*2 With auto switch : -10 to 60°C*2 | | | | |
| Piston speed | 50 to 500 mm/s | | | | |
| Cushion | Air cushion | | | | |
| Stroke length tolerance | Up to 250 st: $^{+1.0}_0$ 251 to 1000 st: $^{+1.4}_0$ 1001 to 1500 st: $^{+1.8}_0$ | | | | |
| Lubrication | Not required (Non-lube) | | | | |
| Mounting | Basic, Axial foot, Rod flange, Head flange, Single clevis, Double clevis, Center trunnion | | | | |

*1 0.05 MPa except locking parts.
 *2 No freezing

Lock Specifications

| Lock position | Head end, Rod end, Double end | | | | |
|--------------------------|--------------------------------|-----|------|------|------|
| Holding force (Max.) (N) | ø40 | ø50 | ø63 | ø80 | ø100 |
| | | 860 | 1340 | 2140 | 3450 |
| Backlash | 2 mm or less | | | | |
| Manual release | Non-locking type, Locking type | | | | |

Accessories/Refer to page 485 for part numbers and dimensions.

| Accessories | Standard | | | | | | Option | |
|-----------------|-------------|------------|---------------------------------|----------------------|---------------------------------|----------|--------|---|
| | Rod end nut | Clevis pin | Lock release bolt (N type only) | Single knuckle joint | Double knuckle joint (with pin) | rod boot | | |
| Mounting | | | | | | | | |
| Basic | ● | — | ● | ● | ● | ● | ● | ● |
| Axial foot | ● | — | ● | ● | ● | ● | ● | ● |
| Rod flange | ● | — | ● | ● | ● | ● | ● | ● |
| Head flange | ● | — | ● | ● | ● | ● | ● | ● |
| Single clevis | ● | — | ● | ● | ● | ● | ● | ● |
| Double clevis* | ● | ● | ● | ● | ● | ● | ● | ● |
| Center trunnion | ● | — | ● | ● | ● | ● | ● | ● |

* Double clevis and double knuckle joint types are packed with pin, split pin and flat washer.

Standard Strokes

| Bore size | Standard stroke (mm) | | | | | | | | | |
|----------------|---|--|--|--|--|--|--|--|--|--|
| 40 | 25, 50, 75, 100, 125, 150, 175, 200, 250, 300, 350, 400, 450, 500 | | | | | | | | | |
| 50, 63 | 25, 50, 75, 100, 125, 150, 175, 200, 250, 300, 350, 400, 450, 500, 600 | | | | | | | | | |
| 80, 100 | 25, 50, 75, 100, 125, 150, 175, 200, 250, 300, 350, 400, 450, 500, 600, 700 | | | | | | | | | |

* Types with auto switch have different minimum strokes. Refer to pages 521 and 522.

* Using a stroke of a length which is smaller than the effective cushion length may result in reduced air cushion performance. Refer to "Technical Data 1" on page 1901 for details on the effective cushion length.

Rod Boot Material

| Symbol | Rod boot material | Max. ambient temperature |
|----------|--------------------------|--------------------------|
| J | Nylon tarpaulin | 70°C |
| K | Heat resistant tarpaulin | 110°C* |

* Maximum ambient temperature for the rod boot itself.

Minimum Stroke for Auto Switch Mounting

⚠ Caution

1. The minimum stroke for mounting varies with the auto switch type and cylinder mounting type. In particular, the center trunnion type needs careful attention. (For details, refer to pages 521 and 522.)

CJ1

CJP

CJ2

JCM

CM2

CM3

CG1

CG3

JMB

MB

MB1

CA2

CS1

CS2

D-□

-X□

Technical Data

CBA2 Series

Weights/Aluminum Tube (Steel Tube)

| Bore size (mm) | | 40 | 50 | 63 | 80 | 100 |
|---------------------|---------------------------------------|--|----------------|----------------|----------------|----------------|
| Basic weight | Basic | 0.89 (0.94) | 1.36 (1.40) | 2.00 (2.04) | 3.48 (3.63) | 4.87 (5.07) |
| | Axial foot | 1.08 (1.13) | 1.58 (1.62) | 2.34 (2.38) | 4.15 (4.30) | 5.86 (6.06) |
| | Flange | 1.26 (1.30) | 1.81 (1.86) | 2.79 (2.84) | 4.93 (5.08) | 6.79 (6.99) |
| | Single clevis | 1.12 (1.17) | 1.70 (1.74) | 2.63 (2.67) | 4.59 (4.74) | 6.65 (6.86) |
| | Double clevis | 1.16 (1.21) | 1.79 (1.84) | 2.79 (2.83) | 4.88 (5.03) | 7.17 (7.38) |
| | Trunnion | 1.25 (1.35) | 1.84 (1.94) | 2.80 (3.00) | 5.03 (5.32) | 7.15 (7.54) |
| | Additional weight per 50 mm of stroke | All mounting brackets (Except steel tube trunnion) | 0.22 (0.28) | 0.28 (0.35) | 0.37 (0.43) | 0.52 (0.70) |
| Steel tube trunnion | | (0.36) | (0.46) | (0.65) | (0.86) | (1.07) |
| Accessories | Single knuckle | 0.23 | 0.26 | 0.26 | 0.60 | 0.83 |
| | Double knuckle (with pin) | 0.37 | 0.43 | 0.43 | 0.87 | 1.27 |

* Values inside the parentheses are those for the steel tube type.

Lock Unit Additional Weights

| Bore size (mm) | | 40 | 50 | 63 | 80 | 100 |
|-------------------------------------|---------------------|------|------|------|------|------|
| Non-locking type manual release (N) | Head end lock (H) | 0.02 | 0.03 | 0.03 | 0.10 | 0.12 |
| | Rod end lock (R) | 0.02 | 0.02 | 0.02 | 0.07 | 0.06 |
| | Double end lock (W) | 0.04 | 0.05 | 0.05 | 0.17 | 0.18 |
| Locking type manual release (L) | Head end lock (H) | 0.04 | 0.05 | 0.05 | 0.13 | 0.15 |
| | Rod end lock (R) | 0.04 | 0.04 | 0.04 | 0.10 | 0.09 |
| | Double end lock (W) | 0.08 | 0.09 | 0.09 | 0.23 | 0.24 |

Calculation: (Example) **CBA2L40-100-HN**

- Basic weight..... 1.08 kg (ø40, Axial foot)
 - Additional weight..... 0.22/50 stroke
 - Cylinder stroke 100 stroke
 - Lock unit weight 0.02 kg
- (Head end lock, Non-locking type manual release)
- $$1.08 + 0.22 \times 100/50 + 0.02 = 1.54 \text{ kg}$$

Mounting Bracket Part No.

| Bore size (mm) | 40 | 50 | 63 | 80 | 100 |
|-----------------|---------|---------|---------|---------|---------|
| Axial foot* | CA2-L04 | CA2-L05 | CA2-L06 | CA2-L08 | CA2-L10 |
| Flange | CA2-F04 | CA2-F05 | CA2-F06 | CA2-F08 | CA2-F10 |
| Single clevis | CA2-C04 | CA2-C05 | CA2-C06 | CA2-C08 | CA2-C10 |
| Double clevis** | CA2-D04 | CA2-D05 | CA2-D06 | CA2-D08 | CA2-D10 |

* When axial foot brackets are used, order two pieces per cylinder.

** A clevis pin, flat washers and split pins are shipped together with double clevis.

Construction

Head end lock

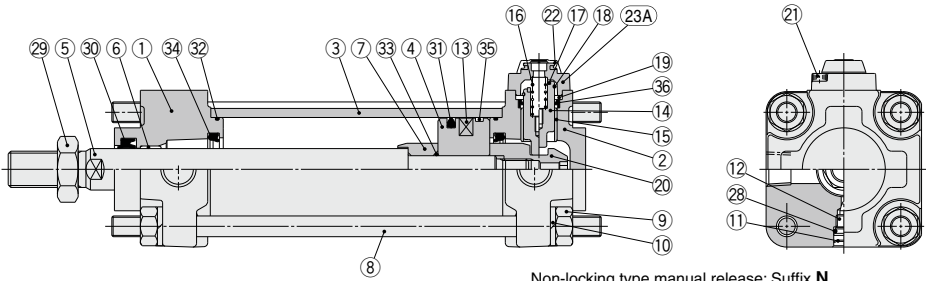

Non-locking type manual release: Suffix N

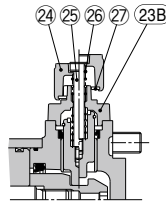

Locking type manual release: Suffix L

Component Parts

| No. | Description | Material | Note |
|-----|-------------------------------|---------------------------|------------------------------------|
| 1 | Rod cover | Aluminum die-casted | Metallic painted |
| 2 | Head cover | Aluminum die-casted | Metallic painted |
| 3 | Cylinder tube | Aluminum alloy | Hard anodized |
| 4 | Piston | Aluminum alloy | Chromated |
| 5 | Piston rod | Carbon steel | Hard chrome plating |
| 6 | Bushing | Bearing alloy | |
| 7 | Cushion ring A | Rolled steel | Electroless nickel plating |
| 8 | Tie-rod | Carbon steel | Zinc chromated |
| 9 | Tie-rod nut | Rolled steel | Trivalent zinc chromated |
| 10 | Spring washer | Steel wire | Trivalent zinc chromated |
| 11 | Retaining ring | Spring steel | Phosphate coating |
| 12 | Cushion valve | Steel wire | Trivalent zinc chromated |
| 13 | Magnet* | — | * With auto switch |
| 14 | Lock piston | Carbon steel | Quench hard chrome plating |
| 15 | Lock bushing | Lead-bronze casted | |
| 16 | Lock spring | Stainless steel | |
| 17 | Bumper | Urethane | |
| 18 | C-ring | Steel wire | Zinc chromated |
| 19 | Seal retainer | Rolled steel | Zinc chromated |
| 20 | Cushion ring nut | Chromium molybdenum steel | Quench, Electroless nickel plating |
| 21 | Hexagon socket head cap screw | Chromium molybdenum steel | Black zinc chromated |
| 22 | Rubber cap | Chloroprene rubber | |
| 23A | Cap A | Aluminum casted | Black coated |
| 23B | Cap B | Carbon steel | Oxide film treated |

| No. | Description | Material | Note |
|-----|----------------------|---------------------------|-----------------------------------|
| 24 | M/O knob | Zinc die-casted | Black coated |
| 25 | M/O bolt | Chromium molybdenum steel | Black zinc chromated, Red painted |
| 26 | M/O spring | Steel wire | Zinc chromated |
| 27 | Stopper ring | Carbon steel | Zinc chromated |
| 28 | Cushion valve seal | NBR | |
| 29 | Rod end nut | Rolled steel | Trivalent zinc chromated |
| 30 | Rod seal | NBR | |
| 31 | Piston seal | NBR | |
| 32 | Cylinder tube gasket | NBR | |
| 33 | Piston gasket | NBR | |
| 34 | Cushion seal | NBR | |
| 35 | Wear ring | Resin | |
| 36 | Lock piston seal | NBR | |

Replacement Parts: Seal Kit

| Bore size (mm) | Kit no. | | Contents |
|----------------|--------------|-----------------|--|
| | One end lock | Double end lock | |
| 40 | MBB40-PS | MBB40-PS-W | Set of the nos. 30, 31, 32, 34, 36. |
| 50 | MBB50-PS | MBB50-PS-W | |
| 63 | MBB63-PS | MBB63-PS-W | |
| 80 | MBB80-PS | MBB80-PS-W | |
| 100 | MBB100-PS | MBB100-PS-W | |

* Seal kit includes 30, 31, 32, 34 and 36. Order the seal kit based on each bore size.

* Do not disassemble the trunnion type. Refer to page 525.

* Seal kit includes a grease pack (ø40, ø50: 10 g, ø63, ø80: 20 g, ø100: 30 g).

Order with the following part number when only the grease pack is needed.

Grease pack part number: GR-S-010 (10 g), GR-S-020 (20 g)

CJ1

CJP

CJ2

JCM

CM2

CM3

CG1

CG3

JMB

MB

MB1

CA2

CS1

CS2

D-□

-X□

Technical Data

CBA2 Series

Basic (Dimensions are common to head end lock, rod end lock and double end lock types.)

Head end lock: CBA2B Bore size – Stroke -HN

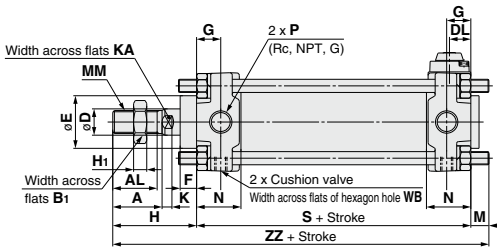

Non-locking type manual release:
Suffix N

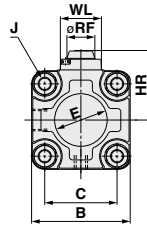

Locking type manual release:
Suffix L

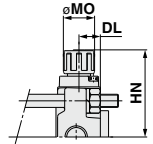

Rod end lock: CBA2B Bore size – Stroke -RN

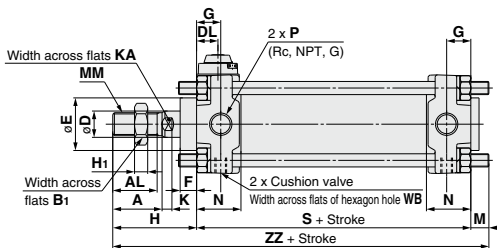

Non-locking type manual release:
Suffix N

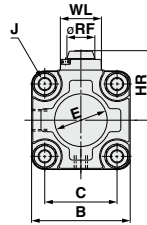

Locking type manual release:
Suffix L

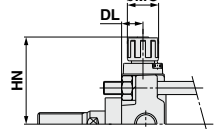

Double end lock: CBA2B Bore size – Stroke -WN

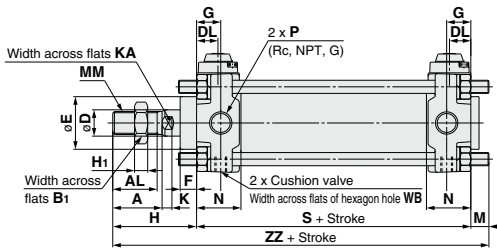

Non-locking type manual release:
Suffix N

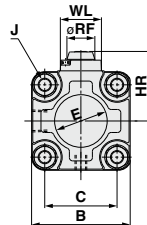

Locking type manual release:
Suffix L

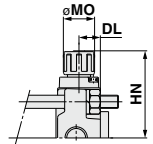

With rod boot

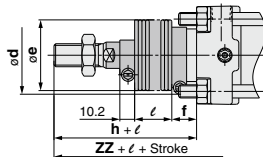

With Rod Boot

| Bore size (mm) | Stroke range (mm) | d | e | f | h | ℓ | ZZ |
|----------------|-------------------|----|----|------|----|------------|-----|
| 40 | 20 to 500 | 56 | 43 | 11.2 | 59 | 1/4 stroke | 154 |
| 50 | 20 to 600 | 64 | 52 | 11.2 | 66 | 1/4 stroke | 167 |
| 63 | 20 to 600 | 64 | 52 | 11.2 | 66 | 1/4 stroke | 178 |
| 80 | 20 to 750 | 76 | 65 | 12.5 | 80 | 1/4 stroke | 213 |
| 100 | 20 to 750 | 76 | 65 | 14 | 81 | 1/4 stroke | 224 |

| Bore size (mm) | Stroke range | A | AL | B | B ₁ | C | D | DL | E | F | G | H | H ₁ | HR | HN (Max.) | J | K | KA | M | MM | MO | N | P | RF | S | WB | WL | ZZ |
|----------------|--------------|----|----|-----|----------------|----|----|------|----|----|----|----|----------------|------|-----------|------------|----|----|----|-----------|----|----|-----|----|-----|-----|----|-----|
| 40 | Up to 500 | 30 | 27 | 60 | 22 | 44 | 16 | 13 | 32 | 10 | 15 | 51 | 8 | 42.3 | 56 | M8 x 1.25 | 6 | 14 | 11 | M14 x 1.5 | 19 | 27 | 1/4 | 17 | 84 | 2.5 | 25 | 146 |
| 50 | Up to 600 | 35 | 32 | 70 | 27 | 52 | 20 | 13 | 40 | 12 | 17 | 58 | 11 | 47.3 | 61 | M8 x 1.25 | 7 | 18 | 11 | M18 x 1.5 | 19 | 30 | 3/8 | 17 | 90 | 2.5 | 25 | 159 |
| 63 | Up to 600 | 35 | 32 | 85 | 27 | 64 | 20 | 15.5 | 40 | 10 | 17 | 58 | 11 | 54.8 | 68.5 | M10 x 1.25 | 7 | 18 | 14 | M18 x 1.5 | 19 | 31 | 3/8 | 17 | 98 | 4 | 25 | 170 |
| 80 | Up to 750 | 40 | 37 | 102 | 32 | 78 | 25 | 18.5 | 52 | 14 | 21 | 71 | 13 | 65.8 | 80.5 | M12 x 1.75 | 11 | 22 | 17 | M22 x 1.5 | 23 | 37 | 1/2 | 21 | 116 | 4 | 40 | 204 |
| 100 | Up to 750 | 40 | 37 | 116 | 41 | 92 | 30 | 20 | 52 | 14 | 21 | 72 | 16 | 72.8 | 87.5 | M12 x 1.75 | 11 | 26 | 17 | M26 x 1.5 | 23 | 40 | 1/2 | 21 | 126 | 4 | 40 | 215 |

The dimensions for each mounting type and the dimensions of accessories (options) are the same as the standard double acting single rod model. Refer to pages 476 to 485.



CBA2 Series

Specific Product Precautions

Be sure to read this before handling the products. Refer to back page 50 for Safety Instructions and pages 3 to 12 for Actuator and Auto Switch Precautions.

Use the Recommended Pneumatic Circuit

⚠ Caution

This is necessary for proper operation and release of the lock.

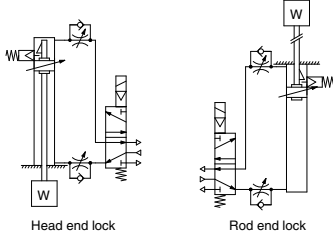

Handling

⚠ Caution

1. Do not use a 3 position solenoid valve.

Avoid using this cylinder in combination with a 3 position solenoid valve (particularly the closed center metal seal type). If air pressure becomes sealed inside the port on the lock mechanism side, the cylinder cannot be locked. Even if the lock is released at first, the air that leaks from the solenoid valve could enter the cylinder and cause the lock to release as time elapses.

2. Back pressure is required to release end lock.

Be sure air is supplied to the side of the cylinder without a lock mechanism (side of the piston rod without lock for double end lock), before starting up, as in the above figures. Otherwise, the lock may not be released. (Refer to "Releasing the Lock".)

3. Release the lock when mounting or adjusting the cylinder.

If mounting or other work is performed when the cylinder is locked, the lock unit may be damaged.

4. Operate with a load ratio of 50% or less.

If the load ratio exceeds 50%, this may cause problems such as failure of the lock to release, or damage to the lock unit.

5. Do not operate multiple synchronized cylinders.

Avoid applications in which two or more cylinders with end lock are synchronized to move one workpiece, as one of the cylinder locks may not be able to release when required.

6. Use a speed controller with meter-out control.

If operated under meter-in control, the lock may not be released.

7. Be sure to operate completely to the cylinder stroke end on the side with the lock.

The lock may not be engaged or released if the piston in the cylinder has not reached the stroke end.

Operating Pressure

⚠ Caution

1. Supply air pressure of 0.15 MPa or higher to the port on the lock mechanism side, as it is necessary for releasing the lock.

Exhaust Speed

⚠ Caution

1. When the pressure on the lock mechanism side drops to 0.05 MPa or below, the lock engages automatically. If the piping on the lock mechanism side is thin and long, or if the speed controller is away from the cylinder port, the lock engagement may take some time to decline of the exhaust speed. The same result will be caused by clogging of the silencer installed at the EXH port of the solenoid valve.

Relation to Cushion

⚠ Caution

1. When the cushion valve on the lock mechanism side is fully closed or almost closed, the piston rod may not be able to reach the stroke end, resulting in lock engagement failure. Furthermore, if the lock becomes engaged while the cushion valve is almost fully closed, it may become impossible to be released. Therefore, the cushion valve must be adjusted properly.

Releasing the Lock

⚠ Caution

1. To release the lock, make sure to supply air pressure to the port on the side without a lock mechanism, thus preventing the load from being applied to the lock mechanism. (Refer to the recommended pneumatic circuits.) If the lock is released, while the port on the side without a lock mechanism is in the exhausted state and the load is being applied to the lock mechanism, undue force may be applied to the lock mechanism, causing the lock mechanism to be damaged. Also, it could be extremely dangerous, because the piston rod could move suddenly.

Manual Release

⚠ Caution

1. Non-locking type manual release

Insert the bolt, which is provided as an accessory, through the rubber cap (it is not necessary to remove the rubber cap). Screw the bolt into the lock piston and pull the bolt to release the lock. Releasing the bolt will re-engage the lock.

The bolt size, pulling force, and the stroke are listed below.

| Bore size (mm) | Thread size | Pulling force | Stroke (mm) |
|----------------|-------------------------|---------------|-------------|
| 40, 50, 63 | M3 x 0.5 x 30 L or more | 10 N | 3 |
| 80, 100 | M5 x 0.8 x 40 L or more | 24.5 N | 3 |

* Remove the bolt for normal operation.

* It can cause lock malfunction or faulty release.

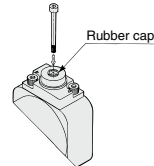

2. Locking type manual release

Push the M/O knob and turn it 90° counterclockwise. The lock is released when the ▲ mark on the cap is aligned with the ▼ OFF mark on the M/O knob (and the lock will remain released).

To engage the lock, push the M/O knob all the way in and turn it 90° clockwise to align the ▲ mark on the cap with the ▼ ON mark on the M/O knob. At this time, make sure that the knob stops by clicking into place.

Failure to click it into place properly can cause the lock to release.

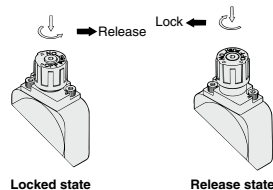

CJ1

CJP

CJ2

JCM

CM2

CM3

CG1

CG3

JMB

MB

MB1

CA2

CS1

CS2

D-□

-X□

Technical Data

Air Cylinder: Air-hydro Type Double Acting, Single Rod

CA2□H Series

ø40, ø50, ø63, ø80, ø100

How to Order

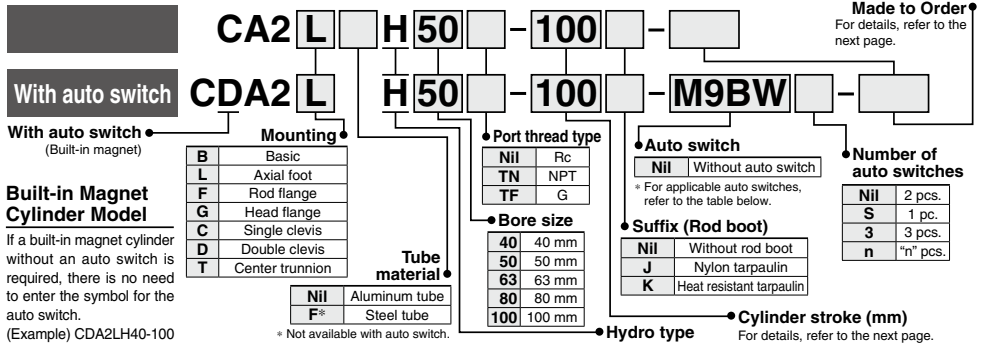

Applicable Auto Switches/Refer to pages 1575 to 1701 for further information on auto switches.

| Type | Special function | Electrical entry | Indicator/light | Wiring (Output) | Load voltage | | Auto switch model | | Lead wire length (m) | | | | | Pre-wired connector | Applicable load |
|--|---|------------------|---------------------|-----------------|--------------|-----------|-------------------|---------------|----------------------|-------|-------|-------|---|---------------------|-----------------|
| | | | | | DC | AC | Tie-rod mounting | Band mounting | 0.5 (Nil) | 1 (M) | 3 (L) | 5 (Z) | | | |
| Solid state auto switch | — | Grommet | — | 3-wire (NPN) | 24 V | 5 V, 12 V | — | M9N | ● | ● | ● | ○ | ○ | IC circuit | — |
| | | | | 3-wire (PNP) | | | | G59 | ● | — | ● | ○ | ○ | | |
| | | | | 2-wire | G5P | ● | — | ● | ○ | ○ | | | | | |
| | | Terminal conduit | | 3-wire (NPN) | 12 V | — | M9B | ● | ● | ● | ○ | ○ | | | |
| | | | | 2-wire | | | K59 | ● | — | ● | ○ | ○ | | | |
| | | | | 3-wire (NPN) | 24 V | 5 V, 12 V | — | G39C | G39 | — | — | — | — | | |
| | 3-wire (PNP) | K39C | K39 | — | | | | — | — | — | | | | | |
| | Diagnostic indication (2-color indicator) | Grommet | Yes | 2-wire | 24 V | 12 V | — | M9NW | ● | ● | ● | ○ | ○ | IC circuit | Relay, PLC |
| | | | | 3-wire (NPN) | | | | G59W | ● | — | ● | ○ | ○ | | |
| | | | | 3-wire (PNP) | M9PW | ● | ● | ● | ○ | ○ | | | | | |
| | | Terminal conduit | | 2-wire | 24 V | 12 V | — | M9B | ● | ● | ● | ○ | ○ | | |
| | | | | 3-wire (NPN) | | | | K59W | ● | — | ● | ○ | ○ | | |
| 3-wire (PNP) | | | | M9NA*1 | — | ○ | ○ | ● | ○ | ○ | | | | | |
| Water resistant (2-color indicator) | Grommet | — | 2-wire | 24 V | 12 V | — | M9PA*1 | — | ○ | ○ | ● | ○ | ○ | — | |
| | | | 3-wire (NPN) | | | | M9BA*1 | — | ○ | ○ | ● | ○ | ○ | | |
| | | | 3-wire (PNP) | M9BA*1 | — | ○ | ○ | ● | ○ | ○ | | | | | |
| | Terminal conduit | | 2-wire | 24 V | 12 V | — | G5BA*1 | — | — | ● | ○ | ○ | | | |
| | | | 3-wire (NPN) | | | | F59F | G59F | ● | — | ● | ○ | ○ | | |
| | | | 3-wire (PNP) | P3DW | — | ● | — | ● | ● | ○ | ○ | | | | |
| With diagnostic output (2-color indicator) | Grommet | Yes | 2-wire (Non-polar) | 24 V | 5 V, 12 V | — | P4DW | — | — | — | — | — | — | | |
| | | | 3-wire (NPN equiv.) | | | | A96** | — | ● | — | ● | — | | — | |
| | | | Terminal conduit | 2-wire | 24 V | 12 V | — | A93** | — | ● | ● | ● | — | | |
| | 3-wire (NPN equiv.) | | | A90** | | | | — | ● | — | ● | — | — | | |
| | DIN terminal | | | A54 | B54 | ● | — | ● | ● | — | | | | | |
| | Diagnostic indication (2-color indicator) | | Grommet | Yes | 2-wire | 24 V | 12 V | — | A33C | A33 | — | — | — | — | — |
| 3-wire (NPN equiv.) | | A34C | | | A34 | | | | — | — | — | — | | | |
| 3-wire (PNP equiv.) | | A44C | | | A44 | — | — | — | — | | | | | | |
| Terminal conduit | 2-wire | 24 V | 12 V | | — | A96** | — | ● | — | ● | — | | | | |
| | 3-wire (NPN equiv.) | | | | | A93** | — | ● | ● | ● | — | | | | |
| | DIN terminal | A54 | B54 | | ● | — | ● | ● | — | | | | | | |

*1 Water resistant type auto switches can be mounted on the above models, but in such case SMC cannot guarantee water resistance. Please contact SMC regarding water resistant types with the above model numbers.

* Lead wire length symbols: 0.5 m..... Nil (Example) M9NW * Solid state auto switches marked with "○" are produced upon receipt of order.
1 m..... M (Example) M9NW **D-A9□ and D-A9□V types cannot be mounted on ø50. Use D-Z7□ and D-Z80 instead.
3 m..... L (Example) M9WL
5 m..... Z (Example) M9WZ

* Since there are other applicable auto switches than listed above, refer to page 523 for details.

* For details about auto switches with pre-wired connector, refer to pages 1648 and 1649.

* The D-A9□/M9□□/P3DW□ auto switches are shipped together, (but not assembled). (However, auto switch mounting brackets are assembled for the D-A9□/M9□□ before shipment.)

Air Cylinder: Air-hydro Type Double Acting, Single Rod **CA2□H Series**



Symbol

Double acting, without cushion

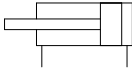

Made to Order
Click here for details

| Symbol | Specifications |
|--------|--|
| -XA□ | Change of rod end shape |
| -XC6 | Made of stainless steel |
| -XC14 | Change of trunnion bracket mounting position |
| -XC15 | Change of tie-rod length |

Note) Since a heavy duty scraper (-XC4) is installed as standard, there is no need to specify it.

⚠ Precautions

Setting

⚠ Caution

- Do not use the cylinder near fire or on equipment or machinery whose ambient temperature exceeds 60°C. Since the air-hydro cylinder uses flammable hydraulic fluid, there is danger of potential fire.

Selection

⚠ Caution

- Keep the air-hydro cylinder load at 50% or less than the theoretical output. For the air-hydro cylinder to achieve performance that is close to that of the hydraulic cylinder in constant-speed operation and stopping accuracy, the load must be kept at 50% or less than theoretical output.

Refer to pages 517 to 523 for cylinders with auto switches.

- Auto switch proper mounting position (detection at stroke end) and its mounting height
- Operating range
- Minimum stroke for auto switch mounting
- Auto switch mounting brackets/Part no.

Specifications

| Bore size (mm) | 40 | 50 | 63 | 80 | 100 |
|-------------------------------|---|----|----|----|-----|
| Type | Air-hydro | | | | |
| Fluid | Turbine oil | | | | |
| Action | Double acting | | | | |
| Proof pressure | 1.5 MPa | | | | |
| Maximum operating pressure | 1.0 MPa | | | | |
| Ambient and fluid temperature | 5 to 60°C | | | | |
| Minimum operating pressure | 0.1 MPa | | | | |
| Piston speed | 0.5 to 300 mm/s | | | | |
| Cushion | None | | | | |
| Stroke length tolerance | Up to 250 st: $^{+1.0}_0$ 251 to 1000 st: $^{+1.4}_0$ 1001 to 1500 st: $^{+1.8}_0$ | | | | |
| Mounting | Basic, Foot, Rod flange, Head flange, Single clevis, Double clevis, Center trunnion | | | | |

Standard Strokes

| Bore size | Standard stroke ^{Note)} (mm) | | Long stroke (L and F only) |
|-----------|---|-----------------|----------------------------|
| | 40 | 50, 63, 80, 100 | |
| 40 | 25, 50, 75, 100, 125, 150, 175, 200, 250, 300, 350, 400, 450, 500 | | 800 |
| 50, 63 | 25, 50, 75, 100, 125, 150, 175, 200, 250, 300, 350, 400, 450, 500, 600 | | 1200 |
| 80, 100 | 25, 50, 75, 100, 125, 150, 175, 200, 250, 300, 350, 400, 450, 500, 600, 700 | | ø80: 1400 ø100: 1500 |

Note) Intermediate strokes not listed above are produced upon receipt of order.

Minimum Stroke for Auto Switch Mounting

⚠ Caution

- The minimum stroke for mounting varies with the auto switch type and cylinder mounting type. In particular, the center trunnion type needs careful attention. (For details, refer to pages 521 and 522.)

Accessories

| Mounting | Basic | Axial foot | Rod flange | Head flange | Single clevis | Double clevis | Center trunnion |
|----------|---------------------------------|------------|------------|-------------|---------------|---------------|-----------------|
| Standard | Rod end nut Clevvis pin | ● — | ● — | ● — | ● — | ● — | ● — |
| Option | Single knuckle joint | ● | ● | ● | ● | ● | ● |
| | Double knuckle joint (with pin) | ● | ● | ● | ● | ● | ● |
| | With rod boot | ● | ● | ● | ● | ● | ● |

* Refer to page 485 for part numbers and dimensions.

Rod Boot Material

| Symbol | Rod boot material | Max. ambient temperature |
|--------|--------------------------|--------------------------|
| J | Nylon tarpaulin | 70°C |
| K | Heat resistant tarpaulin | 110°C* |

* Maximum ambient temperature for the rod boot itself.

Weights/Aluminum Tube (Steel Tube)

| Bore size (mm) | | (kg) | | | | |
|----------------|---|--|----------------|----------------|----------------|----------------|
| | | 40 | 50 | 63 | 80 | 100 |
| Basic weight | Basic | 0.89 (0.94) | 1.36 (1.40) | 2.00 (2.04) | 3.48 (3.63) | 4.87 (5.07) |
| | Axial foot | 1.08 (1.13) | 1.58 (1.62) | 2.34 (2.38) | 4.15 (4.30) | 5.86 (6.06) |
| | Flange | 1.26 (1.30) | 1.81 (1.86) | 2.79 (2.84) | 4.93 (5.08) | 6.79 (6.99) |
| | Single clevis | 1.12 (1.17) | 1.70 (1.74) | 2.63 (2.67) | 4.59 (4.74) | 6.65 (6.86) |
| | Double clevis | 1.16 (1.21) | 1.79 (1.83) | 2.79 (2.83) | 4.88 (5.03) | 7.17 (7.38) |
| | Trunnion | 1.25 (1.35) | 1.84 (1.94) | 2.80 (3.00) | 5.03 (5.32) | 7.15 (7.54) |
| | Additional weight per 50 mm of stroke | All mounting brackets (Except steel tube trunnion) | 0.22 (0.28) | 0.28 (0.35) | 0.37 (0.43) | 0.52 (0.70) |
| Accessories | Steel tube trunnion | 0.36 | 0.46 | 0.65 | 0.86 | 1.07 |
| | Single knuckle Double knuckle (with pin) | 0.23 0.37 | 0.26 0.43 | 0.26 0.43 | 0.60 0.87 | 0.83 1.27 |

Calculation:
(Example)
CA2LH40-100
(Axial foot, ø40, 100 stroke)

- Basic weight
.....1.08 kg
- Additional weight
.....0.22/50 stroke
- Cylinder stroke
.....100 stroke

1.08 + 0.22 x
100/50 = **1.52 kg**

* Values inside the parentheses are those for the steel tube type.

CJ1

CJP

CJ2

JCM

CM2

CM3

CG1

CG3

JMB

MB

MB1

CA2

CS1

CS2

D-□

-X□

Technical Data

CA2□H Series

Mounting Bracket Part No.

| Bore size (mm) | 40 | 50 | 63 | 80 | 100 |
|-----------------|---------|---------|---------|---------|---------|
| Axial foot* | CA2-L04 | CA2-L05 | CA2-L06 | CA2-L08 | CA2-L10 |
| Flange | CA2-F04 | CA2-F05 | CA2-F06 | CA2-F08 | CA2-F10 |
| Single clevis | CA2-C04 | CA2-C05 | CA2-C06 | CA2-C08 | CA2-C10 |
| Double clevis** | CA2-D04 | CA2-D05 | CA2-D06 | CA2-D08 | CA2-D10 |

* When axial foot brackets are used, order two pieces per cylinder.

** A clevis pin, flat washers and split pins are shipped together with double clevis.

Construction

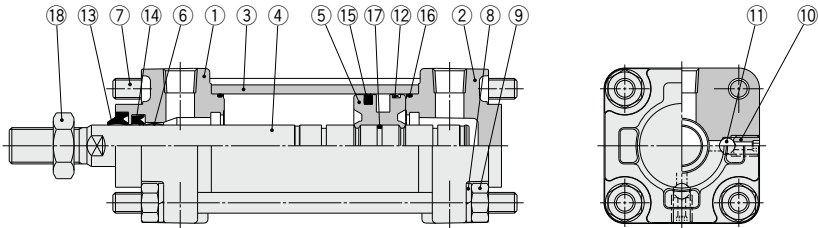

Component Parts

| No. | Description | Material | Note |
|-----|----------------------|---------------------------|--------------------------|
| 1 | Rod cover | Aluminum alloy | Metallic painted |
| 2 | Head cover | Aluminum alloy | Metallic painted |
| 3 | Cylinder tube | Aluminum alloy | Hard anodized |
| 4 | Piston rod | Carbon steel | Hard chrome plating |
| 5 | Piston | Aluminum alloy | Chromated |
| 6 | Bushing | Bearing alloy | |
| 7 | Tie-rod | Carbon steel | Trivalent zinc chromated |
| 8 | Spring washer | Rolled steel | Trivalent zinc chromated |
| 9 | Tie-rod nut | Rolled steel | Trivalent zinc chromated |
| 10 | Air release valve | Chromium molybdenum steel | Black zinc chromated |
| 11 | Check ball | Bearing steel | |
| 12 | Wear ring | Resin | |
| 13 | Scraper | NBR | |
| 14 | Rod seal | NBR | |
| 15 | Piston seal | NBR | |
| 16 | Cylinder tube gasket | NBR | |
| 17 | Piston gasket | NBR | |
| 18 | Rod end nut | Rolled steel | Trivalent zinc chromated |

Replacement Parts: Seal Kit

| Bore size (mm) | Kit no. | | Contents |
|----------------|----------------|--|-----------------------------|
| | Air-hydro type | | |
| 40 | CA2H40A-PS | | Set of the nos. ⑭, ⑮, ⑯. |
| 50 | CA2H50A-PS | | |
| 63 | CA2H63A-PS | | |
| 80 | CA2H80A-PS | | |
| 100 | CA2H100A-PS | | |

* Do not disassemble the trunnion type. Refer to page 525.

* Seal kit includes ⑭, ⑮ and ⑯. Order the seal kit based on each bore size.

* Seal kit includes a grease pack (ø40, ø50: 10 g, ø63 or more: 20 g).

Order with the following part number when only the grease pack is needed.

Grease pack part number: GR-S-010 (10 g), GR-S-020 (20 g)

Air Cylinder: Air-hydro Type Double Acting, Single Rod **CA2□H Series**

Basic: CA2BH

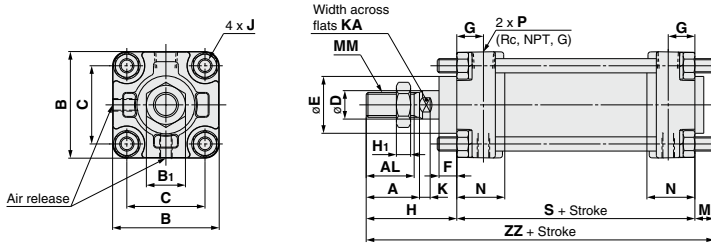

With rod boot

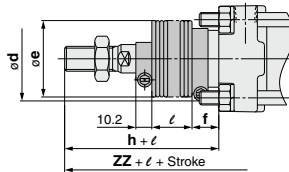

| Bore size (mm) | Stroke range (mm) | | A | AL | B | B ₁ | C | D | E | F | G | H ₁ | J | K | KA | M | MM | N | P |
|----------------|-------------------|---------------|----|----|-----|----------------|----|----|----|----|----|----------------|------------|----|----|----|-----------|----|-----|
| | Without rod boot | With rod boot | | | | | | | | | | | | | | | | | |
| 40 | Up to 500 | 20 to 500 | 30 | 27 | 60 | 22 | 44 | 16 | 32 | 10 | 15 | 8 | M8 x 1.25 | 6 | 14 | 11 | M14 x 1.5 | 27 | 1/4 |
| 50 | Up to 600 | 20 to 600 | 35 | 32 | 70 | 27 | 52 | 20 | 40 | 10 | 17 | 11 | M8 x 1.25 | 7 | 18 | 11 | M18 x 1.5 | 30 | 3/8 |
| 63 | Up to 600 | 20 to 600 | 35 | 32 | 85 | 27 | 64 | 20 | 40 | 10 | 17 | 11 | M10 x 1.25 | 7 | 18 | 14 | M18 x 1.5 | 31 | 3/8 |
| 80 | Up to 750 | 20 to 750 | 40 | 37 | 102 | 32 | 78 | 25 | 52 | 14 | 21 | 13 | M12 x 1.75 | 10 | 22 | 17 | M22 x 1.5 | 37 | 1/2 |
| 100 | Up to 750 | 20 to 750 | 40 | 37 | 116 | 41 | 92 | 30 | 52 | 14 | 21 | 16 | M12 x 1.75 | 10 | 26 | 17 | M26 x 1.5 | 40 | 1/2 |

| Bore size (mm) | S | Without rod boot | | With rod boot | | | | | |
|----------------|-----|------------------|-----|---------------|----|------|----|------------|-----|
| | | H | ZZ | d | e | f | h | ℓ | ZZ |
| 40 | 84 | 51 | 146 | 56 | 43 | 11.2 | 59 | 1/4 stroke | 154 |
| 50 | 90 | 58 | 159 | 64 | 52 | 11.2 | 66 | 1/4 stroke | 167 |
| 63 | 98 | 58 | 170 | 64 | 52 | 11.2 | 66 | 1/4 stroke | 178 |
| 80 | 116 | 71 | 204 | 76 | 65 | 12.5 | 80 | 1/4 stroke | 213 |
| 100 | 126 | 72 | 215 | 76 | 65 | 14 | 81 | 1/4 stroke | 224 |

The dimensions for each mounting type and the dimensions of accessories (options) are the same as the standard double acting single rod model. Refer to pages 476 to 485.

- CJ1
- CJP
- CJ2
- JCM
- CM2
- CM3
- CG1
- CG3
- JMB
- MB
- MB1
- CA2**
- CS1
- CS2

- D-□
- X□
- Technical Data

Air Cylinder: Air-hydro Type Double Acting, Double Rod

CA2W□H Series

ø40, ø50, ø63, ø80, ø100

How to Order

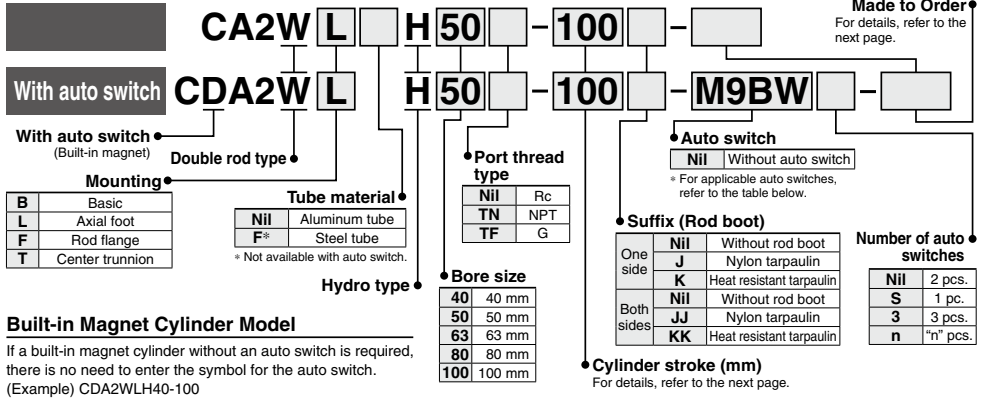

Built-in Magnet Cylinder Model

If a built-in magnet cylinder without an auto switch is required, there is no need to enter the symbol for the auto switch.
(Example) CDA2WLH40-100

Applicable Auto Switches/Refer to pages 1575 to 1701 for further information on auto switches.

| Type | Special function | Electrical entry | Indicator light | Wiring (Output) | Load voltage | | Auto switch model | | Lead wire length (m) | | | | | Pre-wired connector | Applicable load |
|--|---|------------------|---------------------|-----------------|--------------|-----------|-------------------|---------------|----------------------|-------|-------|-------|------------|---------------------|-----------------|
| | | | | | DC | AC | Tie-rod mounting | Band mounting | 0.5 (Nil) | 1 (M) | 3 (L) | 5 (Z) | | | |
| Solid state auto switch | — | Grommet | — | 3-wire (NPN) | 24 V | 5 V, 12 V | — | M9N | ● | ● | ● | ○ | ○ | IC circuit | — |
| | | | | 3-wire (PNP) | | | | G59 | ● | ● | ● | ○ | ○ | | |
| | | | | 2-wire | | | | M9P | ● | ● | ● | ○ | ○ | | |
| | | | | — | | | | G5P | ● | ● | ● | ○ | ○ | | |
| | | | | — | | | | M9B | ● | ● | ● | ○ | ○ | | |
| | | | | — | | | | K59 | ● | ● | ● | ○ | ○ | | |
| | Diagnostic indication (2-color indicator) | Terminal conduit | Yes | 3-wire (NPN) | 12 V | 5 V, 12 V | — | G39C | ● | ● | ● | ○ | ○ | IC circuit | Relay, PLC |
| | | | | 2-wire | | | | G39 | ● | ● | ● | ○ | ○ | | |
| | | | | 3-wire (NPN) | | | | K39C | ● | ● | ● | ○ | ○ | | |
| | | | | 3-wire (PNP) | | | | M9NW | ● | ● | ● | ○ | ○ | | |
| | | | | 2-wire | | | | G59W | ● | ● | ● | ○ | ○ | | |
| | | | | — | | | | M9PW | ● | ● | ● | ○ | ○ | | |
| Water resistant (2-color indicator) | Grommet | — | 2-wire | 24 V | 12 V | — | M9BW | ● | ● | ● | ○ | ○ | — | — | |
| | | | 3-wire (NPN) | | | | K59W | ● | ● | ● | ○ | ○ | | | |
| | | | 3-wire (PNP) | | | | M9NA*1 | — | ○ | ○ | ○ | ○ | | | |
| | | | 2-wire | | | | M9PA*1 | — | ○ | ○ | ○ | ○ | | | |
| | | | — | | | | M9BA*1 | — | ○ | ○ | ○ | ○ | | | |
| | | | — | | | | G5BA*1 | — | ○ | ○ | ○ | ○ | | | |
| With diagnostic output (2-color indicator) Magnetic field resistant (2-color indicator) | Grommet | — | 4-wire (NPN) | 24 V | 5 V, 12 V | — | F59F | ● | ● | ● | ○ | ○ | IC circuit | — | |
| | | | 2-wire (Non-polar) | | | | P3DW | ● | ● | ● | ○ | ○ | | | |
| | | | — | | | | P4DW | ● | ● | ● | ○ | ○ | | | |
| | | | — | | | | A96** | ● | ● | ● | ○ | ○ | | | |
| | | | — | | | | A93** | ● | ● | ● | ○ | ○ | | | |
| | | | — | | | | A90** | ● | ● | ● | ○ | ○ | | | |
| Read auto switch | Grommet | Yes | 3-wire (NPN equiv.) | 24 V | 12 V | — | A54 | ● | ● | ● | ○ | ○ | IC circuit | Relay, PLC | |
| | | | | | | | — | B54 | ● | ● | ● | ○ | | | ○ |
| | | | | | | | — | A64 | ● | ● | ● | ○ | | | ○ |
| | | | | | | | — | A33C | ● | ● | ● | ○ | | | ○ |
| | | | | | | | — | A34C | ● | ● | ● | ○ | | | ○ |
| | | | | | | | — | A44C | ● | ● | ● | ○ | | | ○ |
| Diagnostic indication (2-color indicator) | Grommet | Yes | 2-wire | — | — | — | A44 | ● | ● | ● | ○ | ○ | — | Relay, PLC | |
| | | | | | | | — | A59W | ● | ● | ● | ○ | | | ○ |
| | | | | | | | — | B59W | ● | ● | ● | ○ | | | ○ |
| | | | | | | | — | — | — | — | — | — | | | — |
| | | | | | | | — | — | — | — | — | — | | | — |
| | | | | | | | — | — | — | — | — | — | | | — |

*1 Water resistant type auto switches can be mounted on the above models, but in such case SMC cannot guarantee water resistance.
Please contact SMC regarding water resistant types with the above model numbers.

* Lead wire length symbols: 0.5 m..... Nil (Example) M9NW * Solid state auto switches marked with "○" are produced upon receipt of order.
1 m..... M (Example) M9NWM **D-A9□ and D-A9□V types cannot be mounted on ø50. Use D-Z7□ and D-Z80 instead.
3 m..... L (Example) M9NWL
5 m..... Z (Example) M9NWX

* Since there are other applicable auto switches than listed above, refer to page 523 for details.

* For details about auto switches with pre-wired connector, refer to pages 1649 and 1649.

* The D-A9□/M9□□/P3DW□ auto switches are shipped together, (but not assembled). (However, auto switch mounting brackets are assembled for the D-A9□/M9□□ before shipment.)

Air Cylinder: Air-hydro Type Double Acting, Double Rod **CA2W□H Series**

Specifications



| Bore size (mm) | 40 | 50 | 63 | 80 | 100 |
|-------------------------------|--|----|----|----|-----|
| Type | Air-hydro | | | | |
| Fluid | Turbine oil | | | | |
| Action | Double acting | | | | |
| Proof pressure | 1.5 MPa | | | | |
| Maximum operating pressure | 1.0 MPa | | | | |
| Minimum operating pressure | 0.16 MPa | | | | |
| Piston speed | 0.5 to 300 mm/s | | | | |
| Ambient and fluid temperature | 5 to 60°C | | | | |
| Cushion | None | | | | |
| Stroke length tolerance | Up to 250 st: ^{+1.0} ₀ , 251 to 750 st: ^{+1.4} ₀ | | | | |
| Mounting | Basic, Axial foot, Rod flange, Center trunnion | | | | |

Standard Strokes

| Bore size | Standard stroke (mm) | | | | | | | | | |
|-----------|---|--|--|--|--|--|--|--|--|--|
| 40 | 25, 50, 75, 100, 125, 150, 175, 200, 250, 300, 350, 400, 450, 500 | | | | | | | | | |
| 50, 63 | 25, 50, 75, 100, 125, 150, 175, 200, 250, 300, 350, 400, 450, 500, 600 | | | | | | | | | |
| 80, 100 | 25, 50, 75, 100, 125, 150, 175, 200, 250, 300, 350, 400, 450, 500, 600, 700 | | | | | | | | | |

* Intermediate strokes not listed above are produced upon receipt of order.

Minimum Stroke for Auto Switch Mounting

⚠ Caution

1. The minimum stroke for mounting varies with the auto switch type and cylinder mounting type. In particular, the center trunnion type needs careful attention. (For details, refer to pages 521 and 522.)

Accessories

Symbol

Without cushion

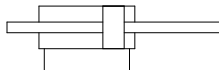

Made to Order
Click here for details

| Symbol | Specifications |
|--------|--|
| -XC6 | Made of stainless steel |
| -XC14 | Change of trunnion bracket mounting position |
| -XC15 | Change of tie-rod length |

Note) Since a heavy duty scraper (-XC4) is installed as standard, there is no need to specify it.

Refer to pages 517 to 523 for cylinders with auto switches.

- Auto switch proper mounting position (detection at stroke end) and its mounting height
- Operating range
- Minimum stroke for auto switch mounting
- Auto switch mounting brackets/Part no.

Rod Boot Material

| Symbol | Rod boot material | Max. ambient temperature |
|--------|--------------------------|--------------------------|
| J | Nylon tarpaulin | 70°C |
| K | Heat resistant tarpaulin | 110°C* |

* Maximum ambient temperature for the rod boot itself.

Weights/Aluminum Tube (Steel Tube)

| Bore size (mm) | | 40 | 50 | 63 | 80 | 100 |
|----------------|---------------------------------------|---|----------------|----------------|----------------|----------------|
| Basic weight | Basic | 1.03 (1.08) | 1.59 (1.64) | 2.26 (2.30) | 3.94 (4.09) | 5.57 (5.78) |
| | Axial foot | 1.22 (1.27) | 1.81 (1.86) | 2.59 (2.63) | 4.61 (4.76) | 6.65 (6.77) |
| | Flange | 1.40 (1.45) | 2.05 (2.09) | 3.05 (3.09) | 5.39 (5.55) | 7.49 (7.70) |
| | Trunnion | 1.39 (1.49) | 2.07 (2.18) | 3.06 (3.25) | 5.49 (5.78) | 7.85 (8.24) |
| | Additional weight per 50 mm of stroke | All mounting brackets (Except steel tube trunnion) | 0.30 (0.35) | 0.40 (0.47) | 0.50 (0.55) | 0.71 (0.89) |
| Accessories | Steel tube trunnion | (0.44) | (0.58) | (0.77) | (1.06) | (1.35) |
| | Single knuckle | 0.23 | 0.26 | 0.26 | 0.60 | 0.83 |
| | Double knuckle (with pin) | 0.37 | 0.43 | 0.43 | 0.87 | 1.27 |

Calculation: (Example) **CA2WLH40-100** (Axial foot, ø40, 100 stroke) * Values inside the parentheses are those for the steel tube type.

- Basic weight..... 1.22 (Axial foot, ø40)
- Additional weight..... 0.30/50 stroke
- Cylinder stroke 100 stroke

$$1.22 + 0.30 \times 100/50 = 1.82 \text{ kg}$$

Mounting Bracket Part No.

| Bore size (mm) | 40 | 50 | 63 | 80 | 100 |
|----------------|---------|---------|---------|---------|---------|
| Axial foot* | CA2-L04 | CA2-L05 | CA2-L06 | CA2-L08 | CA2-L10 |
| Flange | CA2-F04 | CA2-F05 | CA2-F06 | CA2-F08 | CA2-F10 |

* When axial foot brackets are used, order two pieces per cylinder.

CJ1

CJP

CJ2

JCM

CM2

CM3

CG1

CG3

JMB

MB

MB1

CA2

CS1

CS2

D-□

-X□

Technical Data

CA2W□H Series

Construction

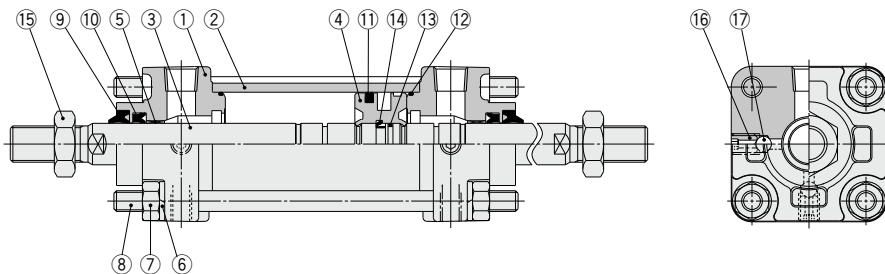

Component Parts

| No. | Description | Material | Note |
|-----|----------------------|---------------------------|----------------------|
| 1 | Rod cover | Aluminum alloy | Metallic painted |
| 2 | Cylinder tube | Aluminum alloy | Hard anodized |
| 3 | Piston rod | Carbon steel | Hard chrome plating |
| 4 | Piston | Aluminum alloy | Chromated |
| 5 | Bushing | Bearing alloy | |
| 6 | Spring washer | Rolled steel | Chromated |
| 7 | Tie-rod nut | Rolled steel | Nickel plating |
| 8 | Tie-rod | Carbon steel | Zinc chromated |
| 9 | Scraper | NBR | |
| 10 | Rod seal | NBR | |
| 11 | Piston seal | NBR | |
| 12 | Cylinder tube gasket | NBR | |
| 13 | Piston gasket | NBR | |
| 14 | Piston holder | Urethane | |
| 15 | Rod end nut | Rolled steel | Nickel plating |
| 16 | Air release valve | Chromium molybdenum steel | Black zinc chromated |
| 17 | Check ball | Bearing steel | |

Replacement Parts: Seal Kit

| Bore size (mm) | Kit no. | Contents |
|----------------|----------------|-----------------------------|
| | Air-hydro type | |
| 40 | CA2WH40A-PS | Set of the nos. ⑩, ⑪, ⑫. |
| 50 | CA2WH50A-PS | |
| 63 | CA2WH63A-PS | |
| 80 | CA2WH80A-PS | |
| 100 | CA2WH100A-PS | |

* Do not disassemble the trunnion type. Refer to page 525.

* Seal kit includes ⑩, ⑪ and ⑫. Order the seal kit based on each bore size.

* Seal kit includes a grease pack (ø40, ø50: 10 g, ø63 or more: 20 g).

Order with the following part number when only the grease pack is needed.

Grease pack part number: GR-S-010 (10 g), GR-S-020 (20 g)

Air Cylinder: Air-hydro Type Double Acting, Double Rod **CA2W□H Series**

Basic: CA2WBH

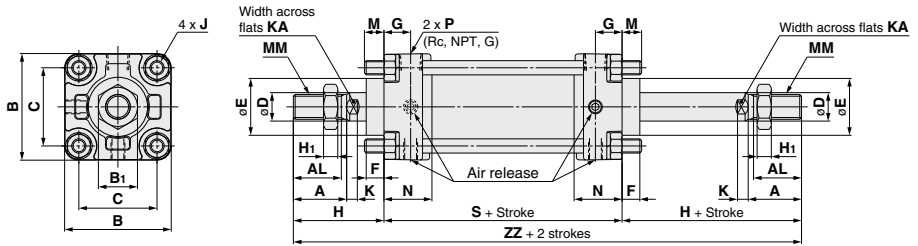

With rod boot (One side)

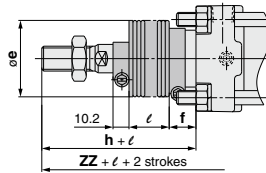

With rod boot (Both sides)

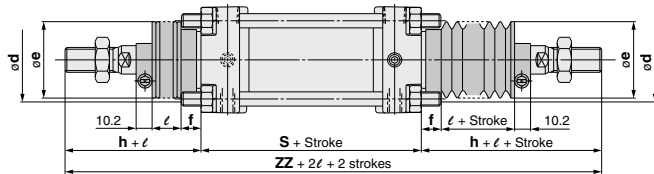

| Bore size (mm) | Stroke range (mm) | | A | AL | B | B ₁ | C | D | E | F | G | H ₁ | J | K | KA | M | MM | N |
|----------------|-------------------|---------------|----|----|-----|----------------|----|----|----|----|----|----------------|------------|----|----|----|-----------|----|
| | Without rod boot | With rod boot | | | | | | | | | | | | | | | | |
| 40 | Up to 500 | 20 to 500 | 30 | 27 | 60 | 22 | 44 | 16 | 32 | 10 | 15 | 8 | M8 x 1.25 | 6 | 14 | 11 | M14 x 1.5 | 27 |
| 50 | Up to 600 | 20 to 600 | 35 | 32 | 70 | 27 | 52 | 20 | 40 | 10 | 17 | 11 | M8 x 1.25 | 7 | 18 | 11 | M18 x 1.5 | 30 |
| 63 | Up to 600 | 20 to 600 | 35 | 32 | 85 | 27 | 64 | 20 | 40 | 10 | 17 | 11 | M10 x 1.25 | 7 | 18 | 14 | M18 x 1.5 | 31 |
| 80 | Up to 750 | 20 to 750 | 40 | 37 | 102 | 32 | 78 | 25 | 52 | 14 | 21 | 13 | M12 x 1.75 | 11 | 22 | 17 | M22 x 1.5 | 37 |
| 100 | Up to 750 | 20 to 750 | 40 | 37 | 116 | 41 | 92 | 30 | 52 | 14 | 21 | 16 | M12 x 1.75 | 11 | 26 | 17 | M26 x 1.5 | 40 |

| Bore size (mm) | P | S | Without rod boot | | With rod boot (One side) | | | | | (Both sides) | |
|----------------|-----|-----|------------------|-----|--------------------------|----|------|----|------------|--------------|-----|
| | | | H | ZZ | d | e | f | h | ℓ | ZZ | ZZ |
| 40 | 1/4 | 84 | 51 | 186 | 56 | 43 | 11.2 | 59 | 1/4 stroke | 194 | 202 |
| 50 | 3/8 | 90 | 58 | 206 | 64 | 52 | 11.2 | 66 | 1/4 stroke | 214 | 222 |
| 63 | 3/8 | 98 | 58 | 214 | 64 | 52 | 11.2 | 66 | 1/4 stroke | 222 | 230 |
| 80 | 1/2 | 116 | 71 | 258 | 76 | 65 | 12.5 | 80 | 1/4 stroke | 267 | 276 |
| 100 | 1/2 | 126 | 72 | 270 | 76 | 65 | 14.0 | 81 | 1/4 stroke | 279 | 288 |

The dimensions for each mounting type are the same as the standard double acting double rod model. Refer to pages 490 to 493. For details about accessories (options), refer to page 485.

- CJ1**
- CJP**
- CJ2**
- JCM**
- CM2**
- CM3**
- CG1**
- CG3**
- JMB**
- MB**
- MB1**
- CA2**
- CS1**
- CS2**

- D**
- X**
- Technical Data

Air Cylinder: Low Friction Type Double Acting, Single Rod

CA2□Q Series

ø40, ø50, ø63, ø80, ø100

Use the new "Smooth Cylinder CA2Y Series" to realize dual-side low friction and low-speed operation. (Refer to the Best Pneumatics No. 2-3.)

How to Order

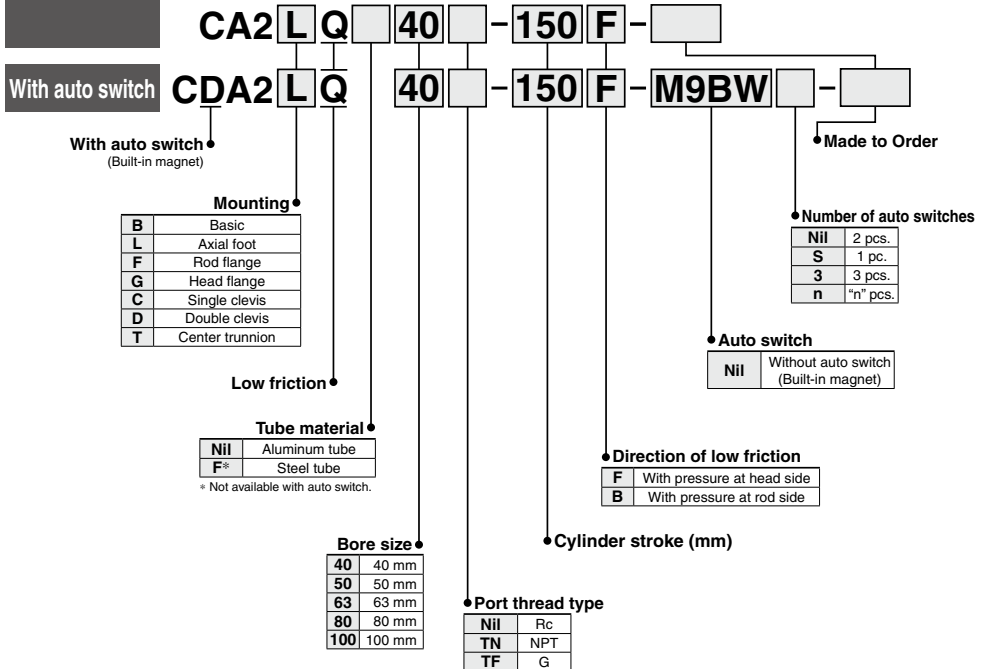

Built-in Magnet Cylinder Model

If a built-in magnet cylinder without an auto switch is required, there is no need to enter the symbol for the auto switch.

(Example) CDA2BQ40-100

CA2 Series Auto Switch Mounting

Auto Switch Proper Mounting Position (Detection at stroke end) and Its Mounting Height

<Band mounting>

D-B5□/B64/B59W

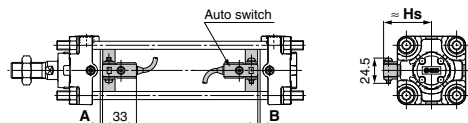

D-A3□
D-G39/K39

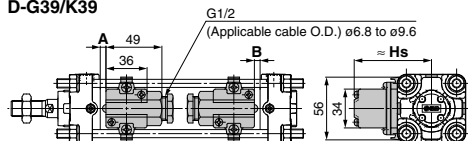

D-G5□/K59 D-G5BA
D-G5□W/K59W D-G59F/G5NT

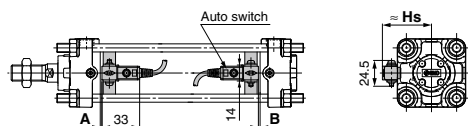

D-A44

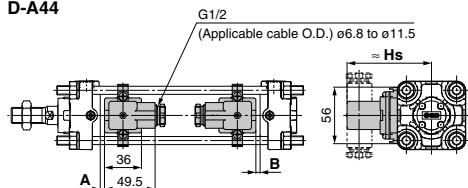

<Tie-rod mounting>

D-M9□/M9□V D-Y59□/Y69□/Y7P/Y7PV
D-M9□W/M9□WV D-Y7□W/Y7□WV
D-M9□A/M9□AV D-Y7BA
D-A9□/A9□V D-Z7□/Z80

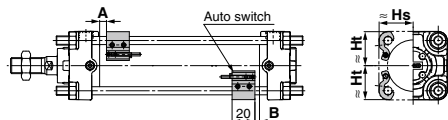

D-A5□/A6□
D-A59W

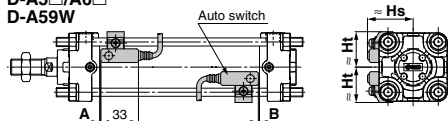

D-G39C/K39C
D-A3□C

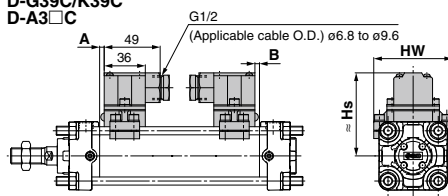

D-F5□/J59 D-F5□W/J59W
D-F5NT D-F5BA/F59F

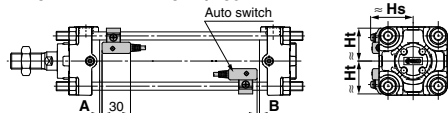

D-A44C

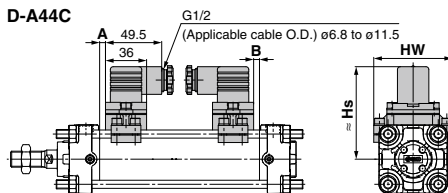

D-P3DWA
D-P3DW

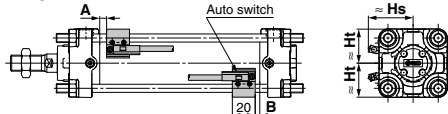

D-P4DW

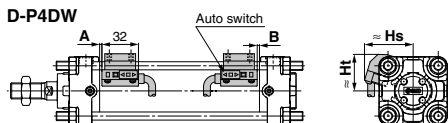

CJ1

CJP

CJ2

JCM

CM2

CM3

CG1

CG3

JMB

MB

MB1

CA2

CS1

CS2

D-□

-X□

Technical
Data

Auto Switch Proper Mounting Position (Detection at stroke end) and Its Mounting Height

Auto Switch Proper Mounting Position (Standard type)

(mm)

| Auto switch model | D-M9□ D-M9□V D-M9□W D-M9□A D-M9□AV | | D-A9□ D-A9□V | | D-Y59□ D-Y69□ D-Y7P D-Y7P D-Y7PW D-Y7□W D-Y7BA D-Z7□ D-Z80 D-B59W | | D-P3DWA | | D-P4DW | | D-F5□ D-J59 D-F59F D-F5□W D-J59W D-F5BA | | D-F5NT | | D-A59W | | D-G39 D-G39C D-K39 D-K39C D-A5□ D-A6□ D-A3□ D-A3□C D-A44 D-A44C | | D-G5□ D-K59 D-G5NT D-G5□W D-K59W D-G5BA D-G59F | | D-B5□ D-B64 | |
|-------------------|--|------|-----------------|-----|--|-----|---------|------|--------|-----|--|------|--------|------|--------|-----|--|-----|--|-----|----------------|-----|
| | A | B | A | B | A | B | A | B | A | B | A | B | A | B | A | B | A | B | A | B | A | B |
| 40 | 9 | 9 | 5 | 5 | 2.5 | 2.5 | 4.5 | 4.5 | 2 | 2 | 5.5 | 5.5 | 10.5 | 10.5 | 3 | 3 | 0 | 0 | 1 | 1 | 0 | 0 |
| 50 | 9.5 | 8.5 | 5.5 | 4.5 | 3 | 2 | 5 | 4 | 2.5 | 1.5 | 6 | 5 | 11 | 10 | 3.5 | 2.5 | 0 | 0 | 1.5 | 0.5 | 0 | 0 |
| 63 | 12.5 | 11.5 | 8.5 | 7.5 | 6 | 5 | 8 | 7 | 5.5 | 4.5 | 9 | 8 | 14 | 13 | 6.5 | 5.5 | 2.5 | 1.5 | 4.5 | 3.5 | 3 | 2 |
| 80 | 16.5 | 13.5 | 12.5 | 9.5 | 10 | 7 | 12 | 9 | 9.5 | 6.5 | 13 | 10 | 18 | 15 | 10.5 | 7.5 | 6.5 | 3.5 | 8.5 | 5.5 | 7 | 4 |
| 100 | 18 | 16 | 14 | 12 | 11.5 | 9.5 | 13.5 | 11.5 | 11 | 9 | 14.5 | 12.5 | 19.5 | 17.5 | 12 | 10 | 8 | 6 | 10 | 8 | 8.5 | 6.5 |

Note) Adjust the auto switch after confirming the operating conditions in the actual setting.

Auto Switch Proper Mounting Height (Standard type)

(mm)

| Auto switch model | D-M9□ D-M9□W D-M9□A D-A9□ | | D-M9□V D-M9□WV D-M9□AV | | D-A9□V | | D-Y59□ D-Y7P D-Y7BA D-Y7□W D-Z7□ D-Z80 | | D-Y69□ D-Y7PV D-Y7□WV | | D-P3DWA | | D-P4DW | | D-G5□ D-K59 D-G5NT D-G5□W D-K59W D-G5BA D-G59F D-B5□ D-B64 D-B59W | | D-G39 D-K39 D-A3□ | | D-A44 | | D-F5□ D-J59 D-F5□W D-J59W D-F5BA D-F59F D-F5NT | | D-A5□ D-A6□ D-A59W | | D-G39C D-K39C D-A3□C | | D-A44C | | |
|-------------------|------------------------------------|----|------------------------------|----|--------|----|---|------|-----------------------------|------|---------|----|--------|------|--|-------|-------------------------|------|-------|------|--|------|--------------------------|------|----------------------------|----|--------|----|----|
| | Hs | Ht | Hs | Ht | Hs | Ht | Hs | Ht | Hs | Ht | Hs | Ht | Hs | Ht | Hs | Ht | Hs | Ht | Hs | Ht | Hs | Ht | Hs | Ht | Hs | Ht | Hs | Ht | Hs |
| 40 | 30 | 30 | 34 | 30 | 31 | 30 | 30 | 30 | 30 | 30 | 37.5 | 35 | 42.5 | 33 | 37 | 71.5 | 81.5 | 38 | 31.5 | 38.5 | 31.5 | 73 | 69 | 81 | 69 | | | | |
| 50 | 34 | 34 | 38 | 34 | 35 | 34 | 34 | 34 | 34 | 34 | 41.5 | 39 | 46.5 | 37.5 | 42 | 76.5 | 86.5 | 42 | 35.5 | 42 | 35.5 | 78.5 | 77 | 86.5 | 77 | | | | |
| 63 | 41 | 41 | 44 | 41 | 41.5 | 41 | 41 | 41 | 41 | 41 | 50 | 41 | 52 | 43 | 49 | 83.5 | 93.5 | 47 | 43 | 46.5 | 43 | 85.5 | 91 | 93.5 | 91 | | | | |
| 80 | 49.5 | 49 | 52.5 | 49 | 50 | 49 | 49.5 | 49 | 49.5 | 49 | 58 | 49 | 58.5 | 51.5 | 57.5 | 92 | 102 | 53.5 | 51 | 53.5 | 51 | 94 | 107 | 102 | 107 | | | | |
| 100 | 56.5 | 56 | 61 | 56 | 58.5 | 56 | 56.5 | 55.5 | 57.5 | 55.5 | 66 | 56 | 66 | 58.5 | 68 | 102.5 | 112.5 | 61 | 57.5 | 61.5 | 57.5 | 104 | 121 | 112 | 121 | | | | |

Auto Switch Proper Mounting Position (Detection at stroke end) and Its Mounting Height

Auto Switch Proper Mounting Position (Non-rotating rod type, With end lock)

(mm)

| Auto switch model | D-M9□ D-M9□V D-M9□W D-M9□A D-M9□AV | | D-A9□ D-A9□V | | D-Y59□ D-Y69□ D-Y7P D-Y7PV D-Y7□W D-Y7□WV | | D-Y59□ D-Y69□ D-Y7P D-Y7PV D-Y7□W D-Y7□WV | | D-P3DWA | | D-P4DW | | D-G39 D-G39C D-K39 D-K39C D-A5□ D-A6□ D-A3□ D-A3□C D-A44 D-A44C | | D-G5□ D-K59 D-G5NT D-G5□W D-K59W D-G5BA D-G59F | | D-B5□ D-B64 | | D-F5□ D-J59 D-F5□W D-J59W D-F5BA | | D-F5NT | | D-A59W | | | |
|-------------------|--|------|-----------------|------|--|-----|--|-----|---------|-----|--------|-----|--|-----|--|-----|----------------|------|--|------|--------|------|--------|---|---|---|
| | A | B | A | B | A | B | A | B | A | B | A | B | A | B | A | B | A | B | A | B | A | B | A | B | A | B |
| 40 | 10 | 8 | 6 | 4 | 4 | 1 | 5.5 | 3.5 | 3.5 | 0.5 | 0.5 | 0 | 2.5 | 0 | 1 | 0 | 7 | 4 | 12 | 9 | 4.5 | 1.5 | | | | |
| 50 | 10 | 8 | 6 | 4 | 3.5 | 1.5 | 5.3 | 3.5 | 3 | 1 | 0 | 0 | 2 | 0 | 0.5 | 0 | 6.5 | 4.5 | 11.5 | 9.5 | 4 | 2 | | | | |
| 63 | 12.5 | 11.5 | 8.5 | 7.5 | 6 | 5 | 8 | 7 | 5.5 | 4.5 | 2.5 | 1.5 | 4.5 | 3.5 | 3 | 2 | 9 | 8 | 14 | 13 | 6.5 | 5.5 | | | | |
| 80 | 16 | 14 | 12 | 10 | 9.5 | 7.5 | 11.5 | 9.5 | 9 | 7 | 6 | 4 | 8 | 6 | 6.5 | 4.5 | 12.5 | 10.5 | 17.5 | 15.5 | 10 | 8 | | | | |
| 100 | 17.5 | 16.5 | 13.5 | 12.5 | 11 | 10 | 13 | 12 | 10.5 | 9.5 | 7.5 | 6.5 | 9.5 | 8.5 | 8 | 7 | 14 | 13 | 19 | 18 | 11.5 | 10.5 | | | | |

Note) Adjust the auto switch after confirming the operating conditions in the actual setting.

Auto Switch Proper Mounting Height (Non-rotating rod type, With end lock)

(mm)

| Auto switch model | D-M9□ D-M9□V D-M9□W D-M9□A D-A9□ | | D-M9□V D-M9□W D-M9□AV | | D-A9□V | | D-Y59□ D-Y7P D-Y7□W D-Y7BA D-Z7□ D-Z80 | | D-Y69□ D-Y7PV D-Y7□WV | | D-P3DWA | | D-P4DW | | D-G5□ D-K59 D-G5□W D-K59W D-G59F D-G5BA D-G5NT D-B5□ D-B64 D-B59W | | D-G39 D-K39 D-A3□ | | D-A44 | | D-F5□ D-J59 D-F5□W D-J59W D-F5BA D-F5NT | | D-A5□ D-A6□ D-A59W | | D-G39C D-K39C D-A3□C | | D-A44C | | | | |
|-------------------|--|----|-----------------------------|----|--------|----|---|------|-----------------------------|------|---------|----|--------|------|--|-------|-------------------------|------|-------|------|--|------|--------------------------|------|----------------------------|----|--------|----|----|----|--|
| | Hs | Ht | Hs | Ht | Hs | Ht | Hs | Ht | Hs | Ht | Hs | Ht | Hs | Ht | Hs | Ht | Hs | Ht | Hs | Ht | Hs | Ht | Hs | Ht | Hs | Ht | Hs | Ht | Hs | Ht | |
| 40 | 30 | 30 | 34 | 30 | 31 | 30 | 30 | 30 | 30 | 30 | 37.5 | 35 | 42.5 | 33 | 37 | 71.5 | 81.5 | 38 | 31.5 | 38.5 | 31.5 | 73 | 69 | 81 | 69 | | | | | | |
| 50 | 34 | 34 | 38 | 34 | 35 | 34 | 34 | 34 | 34 | 34 | 41.5 | 39 | 46.5 | 37.5 | 42 | 76.5 | 86.5 | 42 | 35.5 | 42 | 35.5 | 78.5 | 77 | 86.5 | 77 | | | | | | |
| 63 | 41 | 41 | 44 | 41 | 41.5 | 41 | 41 | 41 | 41 | 41 | 50 | 41 | 52 | 43 | 49 | 83.5 | 93 | 47 | 43 | 46.5 | 43 | 85.5 | 91 | 93.5 | 91 | | | | | | |
| 80 | 49.5 | 49 | 52.5 | 49 | 50 | 49 | 49.5 | 49 | 49.5 | 49 | 58 | 49 | 58.5 | 51.5 | 57.5 | 92 | 102 | 53.5 | 51 | 53.5 | 51 | 94 | 107 | 102 | 107 | | | | | | |
| 100 | 56.5 | 56 | 61 | 56 | 58.5 | 56 | 58.5 | 55.5 | 57.5 | 55.5 | 66 | 56 | 66 | 58.5 | 68 | 102.5 | 112.5 | 61 | 57.5 | 61.5 | 57.5 | 104 | 121 | 112 | 121 | | | | | | |

CJ1

CJP

CJ2

JCM

CM2

CM3

CG1

CG3

JMB

MB

MB1

CA2

CS1

CS2

D-□

-X□

Technical Data

CA2 Series

Auto Switch Proper Mounting Position (Detection at stroke end) and Its Mounting Height

Auto Switch Proper Mounting Position (Air-hydro type)

(mm)

| Auto switch model | D-M9□ D-M9□V D-M9□W D-M9□WV D-M9□A D-M9□AV | | D-A9□ D-A9□V | | D-Y59□ D-Y69□ D-Y7P D-Y7P D-Y7□W D-Y7□WV D-Y7BA D-B59W D-Z7□ D-Z80 | | D-P3DW | | D-P4DW | | D-G39 D-G39C D-K39 D-K39C D-A5□ D-A6□ D-A3□ D-A3□C D-A44 D-A44C | | D-G5□ D-K59 D-G5NT D-G5□W D-K59W D-G5BA D-G59F | | D-B5□ D-B64 | | D-F5□ D-J59 D-F59F D-F5□W D-J59W D-F5BA | | D-F5NT | | D-A59W | | |
|-------------------|---|------|-----------------|------|---|-----|--------|-----|--------|---|--|-----|--|-----|----------------|-----|--|------|--------|------|--------|------|---|
| | A | B | A | B | A | B | A | B | A | B | A | B | A | B | A | B | A | B | A | B | A | B | A |
| 40 | 9.5 | 8.5 | 5.5 | 4.5 | 3.5 | 1.5 | 5.5 | 3.5 | 3 | 1 | 0 | 0 | 2 | 0 | 0.5 | 0 | 6.5 | 4.5 | 11.5 | 9.5 | 4 | 2 | |
| 50 | 10 | 8 | — | — | 3.5 | 1.5 | 5.5 | 3.5 | 3 | 1 | 0 | 0 | 2 | 0 | 0.5 | 0 | 6.5 | 4.5 | 11.5 | 9.5 | 4 | 2 | |
| 63 | 12.5 | 11.5 | 8.5 | 7.5 | 6 | 5 | 3 | 1.5 | 5.5 | 4 | 2.5 | 1.5 | 4.5 | 3.5 | 3 | 2 | 9 | 8 | 14 | 13 | 6.5 | 5.5 | |
| 80 | 16 | 14 | 12 | 10 | 9.5 | 7.5 | 6 | 4.5 | 9 | 7 | 6 | 4 | 8 | 6 | 6.5 | 4.5 | 4.5 | 12.5 | 17.5 | 15.5 | 10 | 8 | |
| 100 | 17.5 | 16.5 | 13.5 | 12.5 | 11 | 10 | 8 | 6.5 | 10.5 | 9 | 7.5 | 6.5 | 9.5 | 8.5 | 8 | 7 | 14 | 13 | 19 | 18 | 11.5 | 10.5 | |

* D-A9□ and D-A9□V types cannot be mounted on ø50.

Note) Adjust the auto switch after confirming the operating conditions in the actual setting.

Auto Switch Proper Mounting Height (Air-hydro type)

(mm)

| Auto switch model | D-M9□ D-M9□V D-M9□A D-A9□ | | D-M9□V D-M9□W D-M9□AV | | D-A9□V | | D-Y59□ D-Y7P D-Y7BA D-Y7□W D-Z7□ D-Z80 | | D-Y69□ D-Y7P D-Y7□WV | | D-P3DW | | D-P4DW | | D-G5□ D-K59 D-G5NT D-G5□W D-K59W D-G5BA D-G59F D-B5□ D-B64 D-B59W | | D-G39 D-K39 D-A3□ | | D-A44 | | D-F5□ D-J59 D-F5□W D-J59W D-F59F D-F5NT | | D-A5□ D-A6□ D-A59W | | D-G39C D-K39C D-A3□C | | D-A44C | | |
|-------------------|------------------------------------|----|-----------------------------|----|--------|----|---|------|----------------------------|------|--------|----|--------|----|--|------|-------------------------|------|-------|------|--|------|--------------------------|------|----------------------------|----|--------|----|----|
| | Hs | Ht | Hs | Ht | Hs | Ht | Hs | Ht | Hs | Ht | Hs | Ht | Hs | Ht | Hs | Ht | Hs | Ht | Hs | Ht | Hs | Ht | Hs | Ht | Hs | Ht | Hs | Ht | Hs |
| 40 | 30 | 30 | 35 | 30 | 32 | 30 | 30 | 30.5 | 30 | 38 | 30 | 43 | 33.5 | 38 | 72.5 | 82.5 | 38.5 | 31 | 40 | 31 | 73 | 69 | 81 | 69 | | | | | |
| 50 | 34 | 34 | 39 | 34 | — | — | 34 | 34 | 35 | 34 | 42 | 34 | 47 | 38 | 43.5 | 78 | 88 | 42.5 | 35 | 43.5 | 35 | 78.5 | 77 | 86.5 | 77 | | | | |
| 63 | 41 | 41 | 46 | 41 | 43.5 | 41 | 41 | 41 | 42.5 | 41 | 49 | 41 | 53 | 44 | 50.5 | 85 | 95 | 48 | 42 | 49 | 42 | 85.5 | 91 | 93.5 | 91 | | | | |
| 80 | 49.5 | 49 | 54 | 49 | 51.5 | 49 | 49.5 | 48.5 | 51 | 48.5 | 56 | 49 | 60 | 52 | 59 | 93.5 | 103.5 | 54 | 50 | 55.5 | 50 | 94 | 107 | 102 | 107 | | | | |
| 100 | 57 | 56 | 62.5 | 56 | 59.5 | 56 | 58.5 | 56 | 59 | 56 | 65 | 56 | 67 | 59 | 69.5 | 104 | 114 | 62 | 57.5 | 63 | 57.5 | 104 | 121 | 112 | 121 | | | | |

* D-A9□ and D-A9□V types cannot be mounted on ø50.

Operating Range

(mm)

| Auto switch model | Bore size | | | | |
|--|------------|------------|------------|------------|-------------|
| | 40 | 50 | 63 | 80 | 100 |
| D-M9□/M9□V D-M9□W/M9□WV D-M9□A/M9□AV | 4.5 | 5 | 5.5 | 5 | 6 |
| D-A9□/A9□V | 7.5 (7) | 8.5 (—) | 9.5 (9) | 9.5 (9) | 10.5 (9) |
| D-Z7□/Z80 | 8.5 | 7.5 | 9.5 | 9.5 | 10.5 |
| D-A3□/A44 D-A3□C/A44C | 9 | 10 | 11 | 11 | 11 |
| D-A5□/A6□ | | | | | |
| D-B5□/B64 | | | | | |
| D-A59W | 13 | 13 | 14 | 14 | 15 |
| D-B59W | 14 | 14 | 17 | 16 | 18 |

| Auto switch model | Bore size | | | | |
|---|-----------|-----|-----|-----|-----|
| | 40 | 50 | 63 | 80 | 100 |
| D-Y59□/Y69□ D-Y7P/Y7□V D-Y7□W/Y7□WV D-Y7BA | 8 | 7 | 5.5 | 6.5 | 6.5 |
| D-F5□/J59/F5□W D-J59W/F5BA D-F5NT/F59F | 4 | 4 | 4.5 | 4.5 | 4.5 |
| D-G5□/K59/G5□W D-K59W/G5BA D-G5NT/G59F | 5 | 6 | 6.5 | 6.5 | 7 |
| D-G39/K39 D-J39C/K39C | 9 | 9 | 10 | 10 | 11 |
| D-P3DWA | 4.5 | 4.5 | 5.5 | 5.5 | 5.5 |
| D-P3DW (Note 3) | 4.5 | 5 | 6 | 5.5 | 6 |
| D-P4DW | 4 | 4 | 4.5 | 4 | 4.5 |

* Values which include hysteresis are for guideline purposes only, they are not a guarantee (assuming approximately ±30% dispersion) and may change substantially depending on the ambient environment.

Note 1) (): For CDA2□H and CDA2W□H Series.

Note 2) D-A9□ and D-A9□V types cannot be mounted on ø50 of the CDA2□H and CDA2W□H series.

Note 3) Applicable to the CDA2□H and CDA2W□H series.

Minimum Stroke for Auto Switch Mounting

| Auto switch model | Number of auto switches | Brackets other than center trunnion | Center trunnion | | | | |
|--|---|---|--|--|--|--|------|
| | | | ø40 | ø50 | ø63 | ø80 | ø100 |
| | | | n: Number of auto switches (mm) | | | | |
| D-M9□ D-M9□W | 2 (Different surfaces and same surface) 1 | 15 | 80 | 85 | 90 | 95 | |
| | n | $15 + 40 \frac{(n-2)}{2}$ (n = 2, 4, 6, 8... Note 1) | $80 + 40 \frac{(n-4)}{2}$ (n = 4, 8, 12, 16... Note 2) | $85 + 40 \frac{(n-4)}{2}$ (n = 4, 8, 12, 16... Note 2) | $90 + 40 \frac{(n-4)}{2}$ (n = 4, 8, 12, 16... Note 2) | $95 + 40 \frac{(n-4)}{2}$ (n = 4, 8, 12, 16... Note 2) | |
| D-M9□V D-M9□WV | 2 (Different surfaces and same surface) 1 | 10 | 55 | 60 | 65 | 70 | |
| | n | $10 + 30 \frac{(n-2)}{2}$ (n = 2, 4, 6, 8... Note 1) | $55 + 30 \frac{(n-4)}{2}$ (n = 4, 8, 12, 16... Note 2) | $60 + 30 \frac{(n-4)}{2}$ (n = 4, 8, 12, 16... Note 2) | $65 + 30 \frac{(n-4)}{2}$ (n = 4, 8, 12, 16... Note 2) | $70 + 30 \frac{(n-4)}{2}$ (n = 4, 8, 12, 16... Note 2) | |
| D-M9□A | 2 (Different surfaces and same surface) 1 | 15 | 80 | 85 | 95 | 100 | |
| | n | $15 + 40 \frac{(n-2)}{2}$ (n = 2, 4, 6, 8... Note 1) | $80 + 40 \frac{(n-4)}{2}$ (n = 4, 8, 12, 16... Note 2) | $85 + 40 \frac{(n-4)}{2}$ (n = 4, 8, 12, 16... Note 2) | $95 + 40 \frac{(n-4)}{2}$ (n = 4, 8, 12, 16... Note 2) | $100 + 40 \frac{(n-4)}{2}$ (n = 4, 8, 12, 16... Note 2) | |
| D-M9□AV | 2 (Different surfaces and same surface) 1 | 10 | 60 | 65 | 70 | 75 | |
| | n | $10 + 30 \frac{(n-2)}{2}$ (n = 2, 4, 6, 8... Note 1) | $60 + 30 \frac{(n-4)}{2}$ (n = 4, 8, 12, 16... Note 2) | $65 + 30 \frac{(n-4)}{2}$ (n = 4, 8, 12, 16... Note 2) | $70 + 30 \frac{(n-4)}{2}$ (n = 4, 8, 12, 16... Note 2) | $75 + 30 \frac{(n-4)}{2}$ (n = 4, 8, 12, 16... Note 2) | |
| D-A9□ | 2 (Different surfaces and same surface) 1 | 15 | 75 | 80 | 85 | 90 | |
| | n | $15 + 40 \frac{(n-2)}{2}$ (n = 2, 4, 6, 8... Note 1) | $75 + 40 \frac{(n-4)}{2}$ (n = 4, 8, 12, 16... Note 2) | $80 + 40 \frac{(n-4)}{2}$ (n = 4, 8, 12, 16... Note 2) | $85 + 40 \frac{(n-4)}{2}$ (n = 4, 8, 12, 16... Note 2) | $90 + 40 \frac{(n-4)}{2}$ (n = 4, 8, 12, 16... Note 2) | |
| D-A9□V | 2 (Different surfaces and same surface) 1 | 10 | 50 | 55 | 60 | 65 | |
| | n | $10 + 30 \frac{(n-2)}{2}$ (n = 2, 4, 6, 8... Note 1) | $50 + 30 \frac{(n-4)}{2}$ (n = 4, 8, 12, 16... Note 2) | $55 + 30 \frac{(n-4)}{2}$ (n = 4, 8, 12, 16... Note 2) | $60 + 30 \frac{(n-4)}{2}$ (n = 4, 8, 12, 16... Note 2) | $65 + 30 \frac{(n-4)}{2}$ (n = 4, 8, 12, 16... Note 2) | |
| D-F5□/J59 D-F5□W/J59W D-F5BA/F59F D-A5□/A6 | 2 (Different surfaces and same surface) 1 | 15 | 90 | 100 | 110 | 120 | |
| | n (Same surface) | $15 + 55 \frac{(n-2)}{2}$ (n = 2, 4, 6, 8... Note 1) | $90 + 55 \frac{(n-4)}{2}$ (n = 4, 8, 12, 16... Note 2) | $100 + 55 \frac{(n-4)}{2}$ (n = 4, 8, 12, 16... Note 2) | $110 + 55 \frac{(n-4)}{2}$ (n = 4, 8, 12, 16... Note 2) | $120 + 55 \frac{(n-4)}{2}$ (n = 4, 8, 12, 16... Note 2) | |
| D-F5NT | 2 (Different surfaces and same surface) 1 | 25 | 110 | 120 | 130 | 140 | |
| | n (Same surface) | $25 + 55 \frac{(n-2)}{2}$ (n = 2, 4, 6, 8... Note 1) | $110 + 55 \frac{(n-4)}{2}$ (n = 4, 8, 12, 16... Note 2) | $120 + 55 \frac{(n-4)}{2}$ (n = 4, 8, 12, 16... Note 2) | $130 + 55 \frac{(n-4)}{2}$ (n = 4, 8, 12, 16... Note 2) | $140 + 55 \frac{(n-4)}{2}$ (n = 4, 8, 12, 16... Note 2) | |
| D-A59W | 2 (Different surfaces and same surface) 1 | 20 | 90 | 100 | 110 | 120 | |
| | n (Same surface) | $20 + 55 \frac{(n-2)}{2}$ (n = 2, 4, 6, 8... Note 1) | $90 + 55 \frac{(n-4)}{2}$ (n = 4, 8, 12, 16... Note 2) | $100 + 55 \frac{(n-4)}{2}$ (n = 4, 8, 12, 16... Note 2) | $110 + 55 \frac{(n-4)}{2}$ (n = 4, 8, 12, 16... Note 2) | $120 + 55 \frac{(n-4)}{2}$ (n = 4, 8, 12, 16... Note 2) | |
| | 1 | 15 | 90 | 100 | 110 | 120 | |
| D-G5□/K59 D-G5□W D-K59W D-G5BA D-G59F D-G5NT D-B5□/B64 | 2 Different surfaces | 15 | 90 | 100 | 110 | | |
| | Same surface | 75 | | | 110 | 120 | |
| | n | Different surfaces | $15 + 50 \frac{(n-2)}{2}$ (n = 2, 4, 6, 8... Note 1) | $90 + 50 \frac{(n-4)}{2}$ (n = 4, 8, 12, 16... Note 2) | $100 + 50 \frac{(n-4)}{2}$ (n = 4, 8, 12, 16... Note 2) | $110 + 50 \frac{(n-4)}{2}$ (n = 4, 8, 12, 16... Note 2) | |
| | | Same surface | $75 + 50 (n-2)$ (n = 2, 3, 4...) | $90 + 50 (n-2)$ (n = 2, 4, 6, 8... Note 1) | $100 + 50 (n-2)$ (n = 2, 4, 6, 8... Note 1) | $110 + 50 (n-2)$ (n = 2, 4, 6, 8... Note 1) | |
| | | | 1 | 10 | 90 | 100 | 110 |
| D-B59W | 2 Different surfaces | 20 | 90 | 100 | 110 | | |
| | Same surface | 75 | | | 110 | 120 | |
| | n | Different surfaces | $20 + 50 \frac{(n-2)}{2}$ (n = 2, 4, 6, 8... Note 1) | $90 + 50 \frac{(n-4)}{2}$ (n = 4, 8, 12, 16... Note 2) | $100 + 50 \frac{(n-4)}{2}$ (n = 4, 8, 12, 16... Note 2) | $110 + 50 \frac{(n-4)}{2}$ (n = 4, 8, 12, 16... Note 2) | |
| | | Same surface | $75 + 50 (n-2)$ (n = 2, 3, 4...) | $90 + 50 (n-2)$ (n = 2, 4, 6, 8... Note 1) | $100 + 50 (n-2)$ (n = 2, 4, 6, 8... Note 1) | $110 + 50 (n-2)$ (n = 2, 4, 6, 8... Note 1) | |
| 1 | 15 | 90 | 100 | 110 | | | |

Note 1) When "n" is an odd number, an even number that is one larger than this odd number is used for the calculation.
 Note 2) When "n" is an odd number, a multiple of 4 that is larger than this odd number is used for the calculation.

CJ1
CJP
CJ2
JCM
CM2
CM3
CG1
CG3
JMB
MB
MB1
CA2
CS1
CS2

D-□
-X□
Technical Data

Minimum Stroke for Auto Switch Mounting

| | | | n: Number of auto switches (mm) | | | | |
|-----------------------------------|---|---|--|--|--|--|--|
| Auto switch model | Number of auto switches | Brackets other than center trunnion | Center trunnion | | | | |
| | | | ø40 | ø50 | ø63 | ø80 | ø100 |
| D-G39 D-K39 D-A3□ | 2 | Different surfaces | 35 | 75 | 80 | 90 | |
| | | Same surface | 100 | 100 | 100 | 100 | |
| | n | Different surfaces | $35 + 30(n-2)$ (n = 2, 3, 4...) | $75 + 30(n-2)$ (n = 2, 4, 6, 8...) ^{Note 1)} | $80 + 30(n-2)$ (n = 2, 4, 6, 8...) ^{Note 1)} | $90 + 30(n-2)$ (n = 2, 4, 6, 8...) ^{Note 1)} | |
| | | Same surface | $100 + 100(n-2)$ (n = 2, 3, 4...) | | $100 + 100(n-2)$ (n = 2, 4, 6, 8...) ^{Note 1)} | | |
| | 1 | 10 | 75 | 80 | 90 | | |
| D-A44 | 2 | Different surfaces | 35 | 75 | 80 | 90 | |
| | | Same surface | 55 | | | | |
| | n | Different surfaces | $35 + 30(n-2)$ (n = 2, 3, 4...) | $75 + 30(n-2)$ (n = 2, 4, 6, 8...) ^{Note 1)} | $80 + 30(n-2)$ (n = 2, 4, 6, 8...) ^{Note 1)} | $90 + 30(n-2)$ (n = 2, 4, 6, 8...) ^{Note 1)} | |
| | | Same surface | $55 + 50(n-2)$ (n = 2, 3, 4...) | $75 + 50(n-2)$ (n = 2, 4, 6, 8...) ^{Note 1)} | $80 + 50(n-2)$ (n = 2, 4, 6, 8...) ^{Note 1)} | $90 + 50(n-2)$ (n = 2, 4, 6, 8...) ^{Note 1)} | |
| | 1 | 10 | 75 | 80 | 90 | | |
| D-G39C D-K39C D-A3□C | 2 | Different surfaces | 20 | 75 | 80 | 90 | |
| | | Same surface | 100 | 100 | 100 | 100 | |
| | n | Different surfaces | $20 + 35(n-2)$ (n = 2, 3, 4...) | $75 + 35(n-2)$ (n = 2, 4, 6, 8...) ^{Note 1)} | $80 + 35(n-2)$ (n = 2, 4, 6, 8...) ^{Note 1)} | $90 + 35(n-2)$ (n = 2, 4, 6, 8...) ^{Note 1)} | |
| | | Same surface | $100 + 100(n-2)$ (n = 2, 3, 4, 5...) | | $100 + 100(n-2)$ (n = 2, 4, 6, 8...) ^{Note 1)} | | |
| | 1 | 10 | 75 | 80 | 90 | | |
| D-A44C | 2 | Different surfaces | 20 | 75 | 80 | 90 | |
| | | Same surface | 55 | 75 | 80 | 90 | |
| | n | Different surfaces | $20 + 35(n-2)$ (n = 2, 3, 4...) | $75 + 35(n-2)$ (n = 2, 4, 6, 8...) ^{Note 1)} | $80 + 35(n-2)$ (n = 2, 4, 6, 8...) ^{Note 1)} | $90 + 35(n-2)$ (n = 2, 4, 6, 8...) ^{Note 1)} | |
| | | Same surface | $55 + 50(n-2)$ (n = 2, 3, 4...) | $75 + 50(n-2)$ (n = 2, 4, 6, 8...) ^{Note 1)} | $80 + 50(n-2)$ (n = 2, 4, 6, 8...) ^{Note 1)} | $90 + 50(n-2)$ (n = 2, 4, 6, 8...) ^{Note 1)} | |
| | 1 | 10 | 75 | 80 | 90 | | |
| D-Y59□/Y7P D-Y7□W D-Z7□/Z80 | 2 (Different surfaces and same surface) 1 | 15 | 80 | 85 | 90 | 95 | 105 |
| | n | $15 + 40 \frac{(n-2)}{2}$ (n = 2, 4, 6, 8...) ^{Note 1)} | $80 + 40 \frac{(n-4)}{2}$ (n = 4, 8, 12, 16...) ^{Note 2)} | $85 + 40 \frac{(n-4)}{2}$ (n = 4, 8, 12, 16...) ^{Note 2)} | $90 + 40 \frac{(n-4)}{2}$ (n = 4, 8, 12, 16...) ^{Note 2)} | $95 + 40 \frac{(n-4)}{2}$ (n = 4, 8, 12, 16...) ^{Note 2)} | $105 + 40 \frac{(n-4)}{2}$ (n = 4, 8, 12, 16...) ^{Note 2)} |
| D-Y69□/Y7PV D-Y7□WV | 2 (Different surfaces and same surface) 1 | 10 | 65 | 75 | 80 | 90 | |
| | n | $10 + 30 \frac{(n-2)}{2}$ (n = 2, 4, 6, 8...) ^{Note 1)} | $65 + 30 \frac{(n-4)}{2}$ (n = 4, 8, 12, 16...) ^{Note 2)} | $75 + 30 \frac{(n-4)}{2}$ (n = 4, 8, 12, 16...) ^{Note 2)} | $80 + 30 \frac{(n-4)}{2}$ (n = 4, 8, 12, 16...) ^{Note 2)} | $90 + 30 \frac{(n-4)}{2}$ (n = 4, 8, 12, 16...) ^{Note 2)} | |
| D-Y7BA | 2 (Different surfaces and same surface) 1 | 20 | 95 | 100 | 105 | 110 | |
| | n | $20 + 45 \frac{(n-2)}{2}$ (n = 2, 4, 6, 8...) ^{Note 1)} | $95 + 45 \frac{(n-4)}{2}$ (n = 4, 8, 12, 16...) ^{Note 2)} | $100 + 45 \frac{(n-4)}{2}$ (n = 4, 8, 12, 16...) ^{Note 2)} | $105 + 45 \frac{(n-4)}{2}$ (n = 4, 8, 12, 16...) ^{Note 2)} | $110 + 45 \frac{(n-4)}{2}$ (n = 4, 8, 12, 16...) ^{Note 2)} | |
| D-P3DWA | 2 (Different surfaces and same surface) 1 | 15 | | 85 | | | |
| | n | $15 + 50 \frac{(n-2)}{2}$ (n = 2, 4, 6, 8...) ^{Note 1)} | | $85 + 50 \frac{(n-4)}{2}$ (n = 4, 8, 12, 16...) ^{Note 2)} | | | |
| D-P3DW ^{Note 3)} | 2 (Different surfaces and same surface) 1 | 15 | | 85 | | | |
| | n | $15 + 50 \frac{(n-2)}{2}$ (n = 2, 4, 6, 8...) ^{Note 1)} | | $85 + 50 \frac{(n-4)}{2}$ (n = 4, 8, 12, 16...) ^{Note 2)} | | | |
| D-P4DW | 2 (Different surfaces and same surface) 1 | 15 | 120 | 130 | 140 | | |
| | n | $15 + 65 \frac{(n-2)}{2}$ (n = 2, 4, 6, 8...) ^{Note 1)} | $120 + 65 \frac{(n-4)}{2}$ (n = 4, 8, 12, 16...) ^{Note 2)} | $130 + 65 \frac{(n-4)}{2}$ (n = 4, 8, 12, 16...) ^{Note 2)} | $140 + 65 \frac{(n-4)}{2}$ (n = 4, 8, 12, 16...) ^{Note 2)} | | |

Note 1) When "n" is an odd number, an even number that is one larger than this odd number is used for the calculation.

Note 2) When "n" is an odd number, a multiple of 4 that is larger than this odd number is used for the calculation.

Note 3) Only applicable to the CDA2□H and CDA2□WH series.

Auto Switch Mounting Brackets/Part No.

<Tie-rod mounting>

| Auto switch model | Bore size (mm) | | | | |
|--|----------------|-----------|-----------|-----------|-----------|
| | 40 | 50 | 63 | 80 | 100 |
| D-M9□/M9□V D-M9□W/M9□WV D-M9□A/M9□AV D-A9□/A9□V | BA7-040 | BA7-040 | BA7-063 | BA7-080 | BA7-080 |
| D-F5□/J59 D-F5□W/J59W D-F59F/F5NT D-A5□/A6□ D-A59W | BT-04 | BT-04 | BT-06 | BT-08 | BT-08 |
| D-G39C/K39C D-A3□C/A44C | BA3-040 | BA3-050 | BA3-063 | BA3-080 | BA3-100 |
| D-Y59□/Y69□ D-Y7P/Y7PV D-Y7W/Y7WV D-Y7BA D-Z7□/Z80 | BA4-040 | BA4-040 | BA4-063 | BA4-080 | BA4-080 |
| D-P3DW | BK7-040S | BK7-040S | BA10-063S | BA10-080S | BA10-080S |
| D-P3DW <small>Note 2)</small> | BMB9-050S | BMB9-050S | BA9T-063S | BA9T-080S | BA9T-080S |
| D-P4DW | BAP2-040 | BAP2-040 | BAP2-063 | BAP2-080 | BAP2-080 |

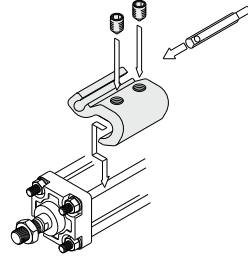

* The figure shows the mounting example for the D-M9□(V)/M9□W(V)/M9□A(V)/A9□(V) types.

<Band mounting>

Except air-hydro type

| Auto switch model | Bore size (mm) | | | | |
|---|----------------|---------|----------|----------|----------|
| | 40 | 50 | 63 | 80 | 100 |
| D-G39/K39 D-A3□/A44 | BDS-04M | BDS-05M | BMB1-063 | BMB1-080 | BMB1-100 |
| D-G5□/K59 D-G5□W/K59W D-G59F D-G5NT D-B5□/B64 D-B59W | BH2-040 | BA5-050 | BAF-06 | BAF-08 | BAF-10 |

Air-hydro type

| Auto switch model | Bore size (mm) | | | | |
|---|----------------|---------|---------|---------|---------|
| | 40 | 50 | 63 | 80 | 100 |
| D-G39/K39 D-A3□/A44 | BD1-04M | BD1-05M | BD1-06M | BD1-08M | BD1-10M |
| D-G5□/K59 D-G5□W/K59W D-G59F D-G5NT D-B5□/B64 D-B59W | BA-04 | BA-05 | BA-06 | BA-08 | BA-10 |

Note 1) Auto switch brackets are included in the D-A3□C/A44C/G39C/K39C types. Specify the part number as follows depending on the cylinder size when ordering.
(Example) ø40: D-A3□C-4, ø50: D-A3□C-5, ø63: D-A3□C-6, ø80: D-A3□C-8, ø100: D-A3□C-10

[Stainless Steel Mounting Screw]

The following stainless steel mounting screw kit (including set screws) is also available. Use it in accordance with the operating environment.
(Since the auto switch mounting bracket and band are not included, order them separately.)

- BBA1: For D-A5/A6/F5/J5 types
- BBA3: For D-B5/B6/G5/K5 types

Note 2) Only applicable to the CDA2□H and CDA2W□H series.

Note 3) Refer to pages 1681 and 1689 for details on the BBA1 and BBA3.

The above stainless steel screws are used when a cylinder is shipped with D-F5BA or G5BA auto switches. When only an auto switch is shipped independently, the BBA1 or BBA3 is attached.

Note 4) When using the D-M9□A(V) or Y7BA, do not use the steel set screws which are included with the above auto switch mounting brackets (BA7-□□□, BA4-□□□). Order a stainless steel screw kit (BBA1) separately, and use the M4 x 6 L stainless steel set screws included in the BBA1.

Note 5) There is a difference in the cylinder tube thickness depending on the cylinder model. Use caution when a band mounting type is used as an applicable auto switch and a cylinder model is changed.

Other than the applicable auto switches listed in "How to Order", the following auto switches are mountable.
Refer to pages 1575 to 1701 for the detailed specifications.

| Type | Model | Electrical entry | Features | |
|-------------|---|------------------------------------|---|--|
| Solid state | D-M9NV/M9PV/M9BV D-Y69A/Y69B/Y7PV D-M9NWV/M9PWV/M9BWW D-Y7NWV/Y7PWV/Y7BWW D-M9NAV/M9PAV/M9BAV | Grommet (Perpendicular) | — | |
| | D-Y59A/Y59B/Y7P D-F59F/F5P/J59 D-Y7NWV/Y7PWV/Y7BW | | Diagnostic indication (2-color indicator) | |
| | D-F59W/F5PW/J59W | | Water resistant (2-color indicator) | |
| | D-F5BA/Y7BA D-F5NT/G5NT D-P5DW | Grommet (In-line) | Diagnostic indication (2-color indicator) | |
| | D-A93V/A96V D-A90V | | Water resistant (2-color indicator) | |
| | D-A53/A56/B53/Z73/Z76 D-A67/Z80 | | With timer | |
| | Reed | D-A93V/A96V D-A90V | Grommet (Perpendicular) | Magnetic field resistant (2-color indicator) |
| | | D-A53/A56/B53/Z73/Z76 D-A67/Z80 | | Without indicator light |
| | | D-A53/A56/B53/Z73/Z76 D-A67/Z80 | Grommet (In-line) | Without indicator light |

* With pre-wired connector is also available for solid state auto switches. For details, refer to pages 1648 and 1649.
* Normally closed (NC = b contact) solid state auto switches (D-M9□E(V)/Y7G/Y7H) are also available. For details, refer to pages 1592-1 and 1595.

- CJ1
- CJP
- CJ2
- JCM
- CM2
- CM3
- CG1
- CG3
- JMB
- MB
- MB1
- CA2
- CS1
- CS2

- D-□
- X□
- Technical Data



1 Cylinder with Heat Resistant Reed Auto Switch (-10 to 120°C)

Symbol
-X1184

Applicable Series

| Description | Model | Action | Note |
|---------------|-------|---------------------------|------|
| Standard type | CA2 | Double acting, Single rod | |

How to Order

CDA2 Standard model no. Z - Pivot bracket Rod end bracket - Heat resistant reed auto switch - X1184

| Switch model | |
|--------------|----------------|
| Symbol | Description |
| Nil | Without switch |
| B30 | D-B30 |
| B30J | D-B30J |
| B31 | D-B31 |
| B31J | D-B31J |
| B35 | D-B35 |
| B35J | D-B35J |

| Number of switches | |
|--------------------|-------------|
| Symbol | Description |
| S | 1 pc. |
| Nil | 2 pcs. |

Cylinder with heat resistant reed auto switch

* For details about auto switches, refer to page 1671.

Specifications

| | |
|---------------------------|-----------------------|
| Ambient temperature range | -10°C to 120°C |
| Seal material | Fluororubber |
| Grease | Heat resistant grease |

Warning Precautions

Be aware that smoking cigarettes etc. after your hands have come into contact with the grease used in this cylinder can create a gas that is hazardous to humans.

Dimensions (Dimensions other than below are the same as standard type.)

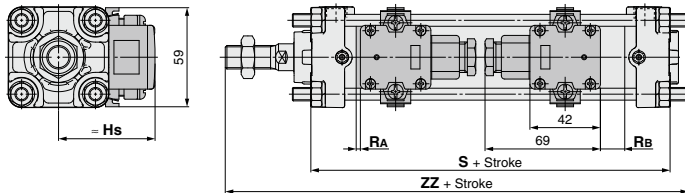

(mm)

| Bore size | Hs | RA | RB | S | ZZ | Minimum mounting stroke | | Auto switch mounting bracket part number |
|-----------|------|-----|------|-----|-----|--|-----------------|--|
| | | | | | | Other than center trunnion | Center trunnion | |
| 40 | 57.5 | 4 | 13 | 99 | 161 | 1 pc. : 50 st or more | 180 st or more | BD1-04M |
| 50 | 62.5 | 4 | 13 | 105 | 174 | | 180 st or more | BD1-05M |
| 63 | 69 | 7 | 16 | 113 | 185 | 2 pcs.: Different surfaces 50 st or more | 190 st or more | BD1-06M |
| 80 | 78 | 5.5 | 23.5 | 131 | 219 | | 200 st or more | BD1-08M |
| 100 | 88.5 | 7.5 | 25.5 | 141 | 230 | 2 pcs.: Same surface 220 st or more | 210 st or more | BD1-10M |



CA2 Series

Specific Product Precautions

Be sure to read this before handling the products. Refer to back page 50 for Safety Instructions and pages 3 to 12 for Actuator and Auto Switch Precautions.

Handling

⚠ Caution

1. **Do not open the cushion valve beyond the stopper.**
A retaining ring is installed as a cushion valve retention mechanism. Do not open the cushion valve beyond it. If not operated in accordance with the above precautions, the cushion valve may be ejected from the cover when air pressure is supplied.

| Bore size (mm) | Width across flats | Socket wrench |
|----------------|--------------------|-----------------------------------|
| 40, 50 | 2.5 | JIS 4648 Hexagonal wrench key 2.5 |
| 63, 80, 100 | 4 | JIS 4648 Hexagonal wrench key 4 |

2. **Use the air cushion at the end of cylinder stroke.**
Otherwise, the tie-rod or piston rod assembly will be damaged.

⚠ Caution

1. **Do not use a pneumatic type as an air-hydro cylinder.** It can cause oil leak.
2. **Do not rotate the piston rod when the rod boot is fixed.**
Before rotating the piston rod, loosen the band to avoid twisting the rod boot.
3. **Install the rod boot with the breathing hole facing downwards or in a direction suitable to prevent dust, moisture etc. from entering easily into the rod boot.**

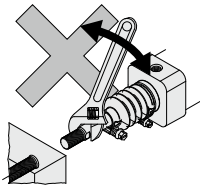

Disassembly/Replacement

⚠ Caution

1. **Use a socket wrench when the bracket is replaced.**
If other tools are used, the nut or other parts may be deformed or the work efficiency may decrease.
For applicable sockets, refer to the table below.

| Bore size (mm) | Nut | Width across flats | Socket | Tightening torque (N·m) |
|----------------|-----------------------------------|--------------------|-----------------------|-------------------------|
| 40, 50 | DA00040 | 13 | JIS B4636 | 7.4 |
| | (M8 x 1.25, Hexagon nut 3 types) | | + Two-angle socket 13 | |
| 63 | DA00010 | 17 | JIS B4636 | 20 |
| | (M10 x 1.25, Hexagon nut 3 types) | | + Two-angle socket 17 | |
| 80, 100 | DA00131 | 19 | JIS B4636 | 29 |
| | (M12 x 1.75, Hexagon nut 3 types) | | + Two-angle socket 19 | |

2. **Do not replace the bushing.**
As the bushing is press-fit, replace the cover assembly when the bushing must be replaced.
3. **When a seal is replaced, apply grease to the new seal before it is assembled.**
Operation of the cylinder without greasing will result in extreme abrasion of the seal, causing premature air leakage.
4. **Do not disassemble the trunnion type cylinder because the mounting precision is required.**
It is difficult to align the axial center of the trunnion with the axial center of the cylinder. Thus, if this type of cylinder is disassembled and reassembled, the required dimensional accuracy cannot be attained, which may lead to malfunctions.

Water Resistant Air Cylinder

Water resistant air cylinders are also available in CA2 series, which are suitable for use on machine tools, where exposure to coolant is possible and applicable for food machinery and automobile washing equipment in an environment where water splashes. Please contact SMC for more information.

CJ1
CJP
CJ2
JCM
CM2
CM3
CG1
CG3
JMB
MB
MB1
CA2
CS1
CS2

D-□
-X□
Technical Data